





**GENERAL NOTES:**

- FOR THE PURPOSE OF THIS PROJECT  
OWNER – TOWN OF WAYLAND, MASSACHUSETTS  
41 COCHITUATE ROAD, TOWN BUILDING  
WAYLAND, MA 01778-2614  
CONTACT – LINDA HANSEN, CONSERVATION ADMINISTRATOR  
ENGINEER – PARE CORPORATION  
10 LINCOLN ROAD, SUITE 210  
FOXBORO, MA 02035  
CONTACT – ALLEN ORSI, P.E.
- ALL CONSTRUCTION INDICATED ON THESE PLANS SHALL BE PERFORMED IN ACCORDANCE WITH THE LATEST EDITION OF THE MASSACHUSETTS STATE BUILDING CODE, THE SPECIFICATIONS INCLUDED IN THIS CONTRACT, AND 302 CMR 10.00 DAM SAFETY. THESE PLANS ARE INCOMPLETE UNLESS ACCOMPANIED BY THE SPECIFICATIONS INCLUDED IN THE CONTRACT DOCUMENTS.
- THE PLANS WERE DEVELOPED FROM A SURVEY PERFORMED BY BAY COLONY GROUP, INC. OF FOXBOROUGH, MA. DATED JANUARY 17, 2020. AS WELL AS AVAILABLE LIDAR DATA THROUGH MASS GIS.
- ELEVATIONS REFERENCE NAVD 1988. HORIZONTAL DATUM REFERENCES NAD 1983. HORIZONTAL AND VERTICAL CONTROL BASED UPON NOAA'S NATIONAL GEODETIC SURVEY (NGS) NATIONAL SPATIAL REFERENCE SYSTEM (NSRS) OPUS SESSION.
- BATHYMETRIC CONTOURS WERE SKETCHED IN BASED ON 1879 HISTORIC PLAN. ACTUAL BATHYMETRIC CONTOURS MAY VARY.
- SEDIMENT/LEAF DEBRIS DEPTH IN THE AREA OF THE LOW LEVEL OUTLET INTAKE WAS APPROXIMATED AT 1 FOOT ABOUT THE PIPE INVERT (WHICH WOULD BE 4+ FEET ABOVE THE BATHYMETRY CONTOURS IN THAT AREA. OTHER AREAS OF SEDIMENT/DEBRIS ACCUMULATION ARE LIKELY. ACTUAL SEDIMENT/DEBRIS DEPTHS MAY VARY.
- BORINGS WERE COMPLETED BY SOIL X, CORP. AND OBSERVED BY PARE PERSONNEL BETWEEN OCTOBER 31 TO NOVEMBER 1, 2019. DEPTHS AND THICKNESS OF THE SUBSURFACE STRATA INDICATED HEREIN ARE GENERALIZED FROM THE SUBSURFACE DATA COLLECTED. INFORMATION SHOWN FOR THE DAM IS INTERPOLATED AND MAY DIFFER. BORING LOGS ARE INCLUDED WITHIN THE SPECIFICATIONS.
- WETLAND FLAGS WERE FLAGGED BY PARE PERSONNEL ON NOVEMBER 6, 2019 WITH SUPPLEMENTAL DELINEATION IN SUPPORT OF ACCESS, STAGING.
- WATER DEPTH MEASUREMENTS TAKEN BY PARE ON OCTOBER 25, 2019 WHILE POOL LEVEL WAS NEAR EL. 225.2±.
- ANY DISCREPANCIES ON THESE PLANS WITH REGARD TO DIMENSIONS OR CONDITIONS SHALL BE BROUGHT TO THE ATTENTION OF THE ENGINEER BEFORE PROCEEDING WITH THE AFFECTED PORTION OF WORK.
- BRUSH AND TREE GROWTH HAS CONTINUED SINCE THE DATE OF THE SURVEY AND SHOULD BE REVIEWED BY THE CONTRACTOR.
- THE CONTRACTOR SHALL BE RESPONSIBLE FOR VERIFYING ALL DIMENSIONS. PLANS SHALL NOT BE SCALED FOR DIMENSIONS.
- CONSTRUCTION SHALL BE MADE FROM APPROVED SHOP DRAWINGS ONLY.
- NOTES, TYPICAL DETAILS AND SCHEDULES APPLY TO ALL WORK UNLESS OTHERWISE NOTED. FOR CONDITIONS NOT SPECIFICALLY SHOWN, PROVIDE DETAILS OF SIMILAR NATURE. VERIFY APPLICABILITY BY SUBMITTING SHOP DRAWINGS FOR REVIEW.
- INFORMATION REGARDING THE LOCATION OF SURROUNDING STRUCTURES, UTILITIES, AND THE AS-BUILT CONFIGURATION AND CONDITION OF THE EXISTING DAM AND OUTLET WORKS IS FURNISHED SOLELY FOR THE CONVENIENCE OF THE CONTRACTOR AND SHALL BE FIELD VERIFIED. THE CONTRACTOR SHALL CONDUCT ITS OWN INDEPENDENT EXAMINATION OF SITE CONDITIONS FOR THE PURPOSE OF BIDDING, FABRICATION, AND CONSTRUCTION ASSOCIATED WITH THE PROJECT. ANY RELIANCE UPON INFORMATION MADE AVAILABLE BY THE OWNER OR THE ENGINEER SHALL BE AT THE CONTRACTOR'S RISK.
- THE CONTRACTOR SHALL PROTECT ALL ADJACENT STRUCTURES AND UTILITIES. THE CONTRACTOR SHALL BE RESPONSIBLE FOR REPAIR OF ALL DAMAGE TO ADJACENT STRUCTURES AND UTILITIES AT NO ADDITIONAL COST TO THE OWNER.
- THE CONTRACTOR SHALL BE RESPONSIBLE FOR DISPOSAL OF ALL PROJECT DEMOLITION AND EXCESS MATERIAL IN ACCORDANCE WITH MASSACHUSETTS, LOCAL, AND FEDERAL LAWS.
- THE CONTRACTOR SHALL FOLLOW ALL OSHA AND OTHER APPLICABLE FEDERAL, STATE, AND LOCAL STANDARDS FOR ALL PROJECT COMPONENTS AND ACTIVITIES. THE CONTRACTOR SHALL BE SOLELY RESPONSIBLE FOR ALL SITE SAFETY PROCEDURES AND PRACTICES REGARDLESS OF THE PRESENCE OF THE OWNER OR ENGINEER.
- ALL CONSTRUCTION ACTIVITIES SHALL BE CONFINED TO THE LIMITS OF WORK AND TEMPORARY EASEMENTS DEFINED HEREIN.
- WHERE REFERENCE IS MADE TO ANY STANDARD SPECIFICATION IT SHALL MEAN THE MOST RECENT SPECIFICATION, CODE, STANDARD, OR INTERIM SPECIFICATIONS OF THE ORGANIZATION REFERRED TO AND SHALL BE CONSIDERED A PART OF THESE CONTRACT DOCUMENTS TO THE EXTENT INDICATED. IN CASE OF CONFLICT, THE MORE RIGID REQUIREMENTS AND CODES SHALL GOVERN. THESE CODES INCLUDE, BUT ARE NOT LIMITED TO: AMERICAN SOCIETY FOR TESTING AND MATERIALS (ASTM).
- THE CONTRACTOR SHALL STAGE ALL EQUIPMENT IN THE DESIGNATED STAGING AREA. ALL GREASING AND REFUELING ACTIVITIES SHALL OCCUR IN THE STAGING AREA.
- THE CONTRACTOR SHALL MAINTAIN A SECURE SITE AND PROVIDE APPROPRIATE SAFETY MEASURES TO PREVENT ACCIDENTS. THE SAFETY MEASURES SHALL INCLUDE, BUT NOT BE LIMITED TO SIGNAGE, BARRICADES, FENCES, FLASHING WARNING LIGHTS, AND POLICING IF NECESSARY.
- NO WORK OR DISCHARGES, OTHER THAN THAT SHOWN, SHALL BE PERFORMED WITHIN WETLANDS WITHOUT FIRST RECEIVING PROPER PERMITS FROM THE REGULATORY AGENCIES. THE CONTRACTOR SHALL BE RESPONSIBLE FOR REMOVING, RESTORING AND REPAIRING ALL DAMAGE AS A RESULT OF UNAUTHORIZED WORK OR DISCHARGES TO THE WETLAND AREA AT NO ADDITIONAL COST TO THE OWNER.
- ALL TREES ARE NOT SURVEY LOCATED AND CONTRACTOR SHALL DETERMINE NUMBER OF TREES REQUIRED FOR REMOVAL.

**DIVERSION NOTES:**

- THE CONTRACTOR SHALL MAINTAIN FLOW THROUGHOUT CONSTRUCTION.
- THE CONTRACTOR SHALL REGULATE DISCHARGES AND PHASE CONSTRUCTION SO THAT CONSTRUCTION EQUIPMENT DOES NOT PASS THROUGH OR ENTER FLOWING WATER.
- ANY NECESSARY COFFERDAMS AND DIVERSIONS SHALL BE DESIGNED AND BEAR THE STAMP OF A PROFESSIONAL ENGINEER. REVIEW AND APPROVAL BY THE OWNER AND ENGINEER IS REQUIRED PRIOR TO INSTALLATION. DESIGN REQUIREMENTS ARE INCLUDED WITHIN SPECIFICATION SECTION 02400.
- THE CONTRACTOR SHALL MAINTAIN A STOCKPILE OF MATERIAL ONSITE TO BE UTILIZED TO STABILIZE THE EXCAVATION IN THE EVENT OF HIGH WATER OR OTHER CONDITIONS WHICH MAY COMPROMISE THE COFFERDAM STABILITY. THE STOCKPILE SHALL BE MAINTAINED IN ACCORDANCE WITH A FLOOD EMERGENCY RESPONSE PLAN TO BE DEVELOPED BY THE CONTRACTOR AND SUBJECT TO APPROVAL BY THE ENGINEER, OWNER, AND OFFICE OF DAM SAFETY.

**EROSION AND SEDIMENT CONTROL NOTES:**

- THE CONTRACTOR SHALL INSTALL AND MAINTAIN EROSION AND SEDIMENT CONTROLS INCLUDING STRAW BALES, SILT FENCE, TURBIDITY BARRIERS, AND ANY OTHER CONTROLS AS INDICATED IN THE CONTRACT DOCUMENTS.
- THE CONTRACTOR SHALL PREVENT SEDIMENT FROM ENTERING THE IMPOUNDMENT VIA DISCHARGES THROUGH ANY DRAINAGE STRUCTURES, COFFERDAMS, OR SEDIMENT CONTROL BARRIER.
- STOCKPILES SHALL BE A MINIMUM OF 1-FOOT FROM THE EDGE OF ANY SLOPE TO LIMIT RUNOFF DOWN THE EMBANKMENT SLOPES.
- EROSION CONTROLS SHALL BE MODIFIED OR EXPANDED AS FIELD CONDITIONS WARRANT.
- ALL EROSION CONTROLS SHALL BE INSPECTED IN ACCORDANCE WITH THE CONTRACTOR'S NPDES SWPPP FOR THIS PROJECT.
- ANY DAMAGED AREAS SHALL BE REPAIRED WITHIN 24 HOURS OF DISCOVERY.
- DEWATERING BASINS SHALL CONSIST OF STRAW BALE ENCLOSURES, TANKS, PERMEABLE BLADDERS, OR OTHER APPROPRIATE METHOD. DEWATERING WASTE WATERS SHALL BE PUMPED TO THE DEWATERING BASINS AND TREATED PRIOR TO DISCHARGE.
- DISCHARGE OF TURBID WATER TO THE RIVER, IMPOUNDMENT, OR ANY WETLAND IS PROHIBITED.
- UPON COMPLETION OF GRADING, ALL EXPOSED SURFACES NOT OTHERWISE TO BE TREATED SHALL BE COVERED WITH A MINIMUM OF 6" OF LOAM AND SEEDED. THE CONTRACTOR SHALL MAINTAIN ALL SEEDED AREAS UNTIL A SATISFACTORY STAND OF HEALTHY GRASS IS ESTABLISHED AS DEFINED IN THE SPECIFICATIONS.

**CONSTRUCTION SEQUENCE:**

THE FOLLOWING SEQUENCE IS INTENDED TO BE GENERAL IN NATURE AND SHALL NOT BE CONSIDERED DIRECTION BY THE ENGINEER OR THE OWNER. ALTHOUGH IT IS LIKELY THAT SOME OF THE WORK ITEMS WILL OVERLAP, CONSTRUCTION SEQUENCES FOR THE VARIOUS PROJECT COMPONENTS ARE DESCRIBED SEPARATELY AND MAY NOT NECESSARILY PROCEED IN CONSECUTIVE ORDER. ALL WORK SHALL BE PERFORMED IN ACCORDANCE WITH THE PROJECT PLANS AND SPECIFICATIONS.

**MOBILIZATION**

- CONTRACTOR MOBILIZATION.
- INSTALL ALL NECESSARY SIGNAGE.
- COMPLETE SITE TREE CLEARING.
- INSTALL PERIMETER EROSION AND SEDIMENT CONTROLS INCLUDING TURBIDITY BARRIER AND SILT FENCE.
- ESTABLISH ACCESS AND STAGING AREAS.

**WATER CONTROL AND DIVERSION**

- IMPLEMENT AND MAINTAIN THE CONSTRUCTION DRAWDOWN.
- INSTALL COFFERDAMS AND DIVERSION SYSTEMS AS NEEDED TO COMPLETE THE WORK.

**TREE AND STUMP REMOVAL**

- REMOVE FALLEN TREES AND OTHER DEBRIS FROM WITHIN THE LIMITS OF WORK.
- CLEAR, GRUB, AND STRIP ALL TREES STUMPS, SHRUBS, BRUSH, WOODY VEGETATION, AND LOAM WITHIN THE LIMITS OF WORK.
- FILL RESULTING VOIDS WITH APPROVED MATERIAL IN COMPACTED LIFTS.

**LOW LEVEL OUTLET WORK**

- REMOVE SEDIMENT AND DEBRIS TO THE EXTENT NEEDED TO COMPLETE THE WORK; COMPLETE CLEAN UP OF THE IMPOUNDMENT BOTTOM.
- CLEAN AND SLOPLINE THE EXISTING 18-INCH LINE WITH A 14-INCH I.D. HDPE CONDUIT. GROUT THE ANNULUS.
- INSTALL THE UPSTREAM GATE VALVE WITH OPERATOR EXTENSION ROD ALONG UPSTREAM SLOPE; INSTALL THE SECONDARY GATE VALVE WITHIN THE GATEHOUSE.
- INSTALL OPERATOR CHAMBER ALONG UPSTREAM EDGE OF CREST.
- INSTALL SCREEN
- CUT AND GROUT THE EXISTING 10-INCH LINE
- EXCAVATE TO REMOVE THE EXISTING STONE CULVERT; BACKFILL TO SUBGRADE FOR THE PROPOSED 14-INCH CONDUIT.
- INSTALL THE 14-INCH CONDUIT AND CRADLE
- INSTALL THE DOWNSTREAM HEADWALL
- BACKFILL THE EXCAVATION.
- INSTALL THE RIPRAP SCOUR APRON

**GATEHOUSE WORK**

- REMOVE THE EXISTING PIPING WITHIN THE GATEHOUSE.
- FILL THE BOTTOM OF THE GATEHOUSE TO WITHIN 1 FOOT OF THE 14-INCH LINE INVERT.
- INSTALL THE 2-INCH DRAIN LINE ALONG AND WITHIN THE CRADLE OF THE 14-INCH LLO OUTLET PIPE.
- INSTALL LADDER RUNGS.
- INSTALL OPERATOR FLOOR.

**SPILLWAY WORK**

- REMOVE DEBRIS AND OTHER MATERIAL TO SUBGRADE FOR THE PROPOSED COMPONENTS AND GRADES. COMPLETE BEDROCK PREPARATION WHERE ENCOUNTERED (REMOVAL TO SOUND BEDROCK; CLEANING; ANCHORS)
- INSTALL THE PROPOSED COMPONENTS INCLUSIVE OF THE CONTROL WEIR, BUBBLER PIPE, TRAINING WALLS, CULVERT, AND RAILINGS.
- BACKFILL ALL COMPONENTS WITH APPROVED MATERIAL IN COMPACTED LIFTS.

**EMBANKMENT WORK**

- INSTALL RIPRAP IN AREAS OF MISSING RIPRAP.
- RAISE THE CORE WALL FROM EL. 225 TO EL. 226.75.
- ESTABLISH A DAM CREST 15 FEET WIDE AT EL. 227.
- REGRADE THE DOWNSTREAM SLOPE TO 2.5H:1V; COMPLETE PREPARATION OF THE GATEHOUSE WALLS PRIOR TO PLACEMENT OF FILLS AGAINST GATEHOUSE.

**WETLAND REPLICATION**

- INSTALL WETLAND REPLICATION.

**PROJECT COMPLETION**

- PLACEMENT OF LOAM AND SEED ON THE DOWNSTREAM SLOPE, CREST, AND ALL AREAS DISTURBED BY THE CONSTRUCTION ACTIVITIES.
- NOTIFY ENGINEER OF SUBSTANTIAL PROJECT COMPLETION.
- DEMOBILIZE AND RETURN DISTURBED AREAS OF THE SITE TO PRE-CONSTRUCTION CONDITIONS.

**LEGEND**

EXISTING		PROPOSED
--- 90 ---	CONTOUR 5'	--- 55 ---
--- 89 ---	CONTOUR 1'	--- 52 ---
---	CART PATH	---
=====	CONCRETE WALL	=====
-----	PROPERTY LINE	-----
----	CLEAN OUT	o CO
-----	EDGE OF WATER	-----
-----	WATER DEPTH MEASUREMENT	-----
-----	EDGE OF WETLAND WETLAND FLAG	-----
-----	100 FT. WETLAND BUFFER	-----
-----	200 FT RIVERBANK AREA	-----
-----	FLOODPLAIN	-----
-----	TURBIDITY BARRIER	-----
=====	COFFERDAM	=====
~~~~~	TREELINE	~~~~~
-----	TREES	-----
-----	SILT FENCE	-----
-----	STRAW BALE	-----
-----	FILTER SOCK	-----
-----	LIMIT OF DISTURBANCE	---LoD---
-----	BORING	-----

**CONTROL POINTS**

**HORIZONTAL:**

POINT ID	COORDINATES	ELEVATION	DESCRIPTION
TBM#1	N: 2946845.116 E: 699041.178	228.772	BOLT
TBM#2	N: 2946737.499 E: 698900.164	204.183	STONE BOUND
TBM#3	N: 2946880.530 E: 698842.038	224.187	FIELD STONE BOUND



SCALE ADJUSTMENT GUIDE  
0" 1"  
BAR IS ONE INCH ON ORIGINAL DRAWING.

**SNAKE BROOK DAM REHABILITATION**  
 MA01119  
 WAYLAND, MASSACHUSETTS  
 TOWN OF WAYLAND CONSERVATION COMMISSION

**REVISIONS:**

PROJECT NO.: 19167.02  
 DATE: NOVEMBER 2022  
 SCALE: AS NOTED  
 DESIGNED BY: MLP  
 CHECKED BY: MED  
 DRAWN BY: LMC  
 APPROVED BY: ARO

GENERAL NOTES AND LEGEND

SHEET NO.: 1.0





SCALE ADJUSTMENT  
 GUIDE  
 0" 1"  
 BAR IS ONE INCH ON  
 ORIGINAL DRAWING.

**SNAKE BROOK DAM REHABILITATION**  
 MA01119  
 WAYLAND, MASSACHUSETTS  
 TOWN OF WAYLAND CONSERVATION COMMISSION

REVISIONS:

PROJECT NO.: 19167.02  
 DATE: NOVEMBER 2022  
 SCALE: AS NOTED  
 DESIGNED BY: MLP  
 CHECKED BY: MED  
 DRAWN BY: LMC  
 APPROVED BY: ARO

FULL IMPOUNDMENT  
 PLAN

SHEET NO.: 2.0

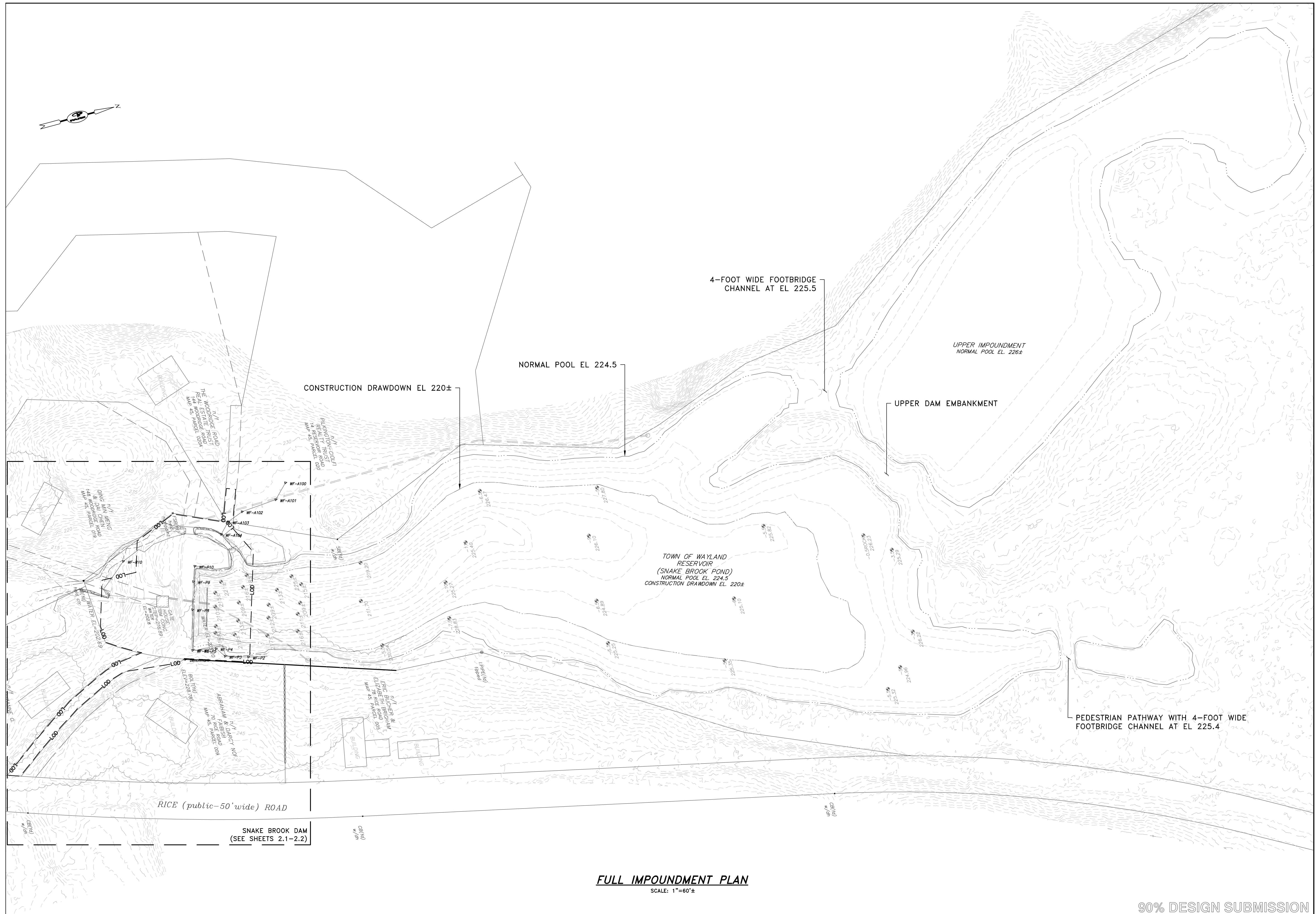

**FULL IMPOUNDMENT PLAN**  
 SCALE: 1"=60'±

90% DESIGN SUBMISSION









SCALE ADJUSTMENT GUIDE  
 0" 1"  
 BAR IS ONE INCH ON ORIGINAL DRAWING.

**SNAKE BROOK DAM REHABILITATION**  
 MA01119  
 WAYLAND, MASSACHUSETTS  
 TOWN OF WAYLAND CONSERVATION COMMISSION

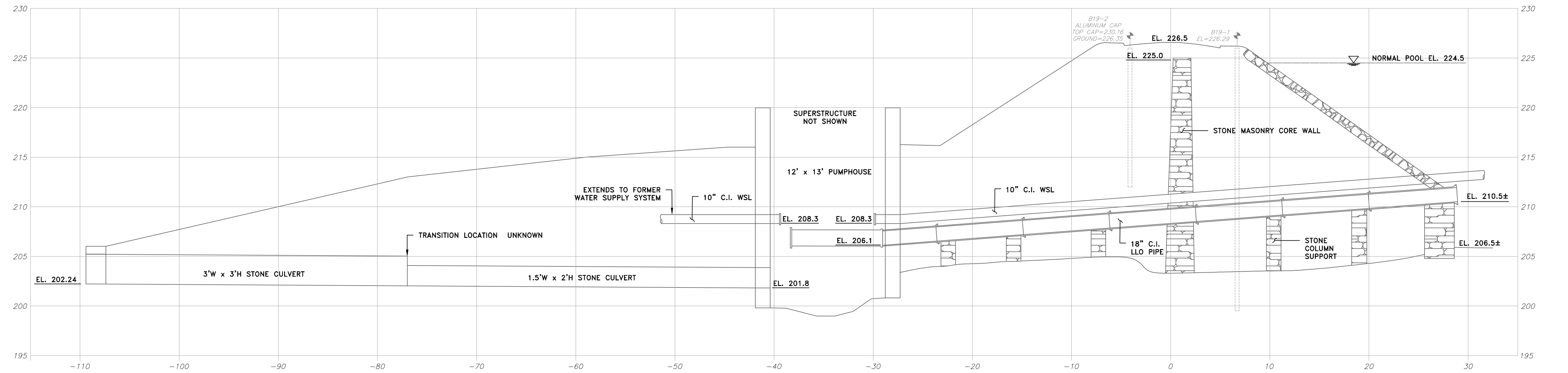

**SECTION A**  
 SCALE: 1"=6'

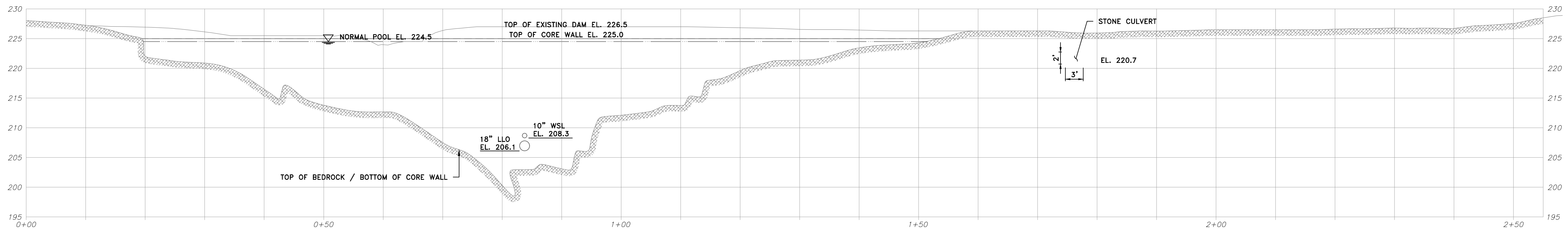

**SECTION B**  
 SCALE: 1"=10'

**NOTE:**  
 BOTH SECTIONS A AND B ON THIS SHEET WERE DEVELOPED UPON INFORMATION PROVIDED WITHIN THE 1897 HISTORICAL DRAWINGS OF THE DAM.

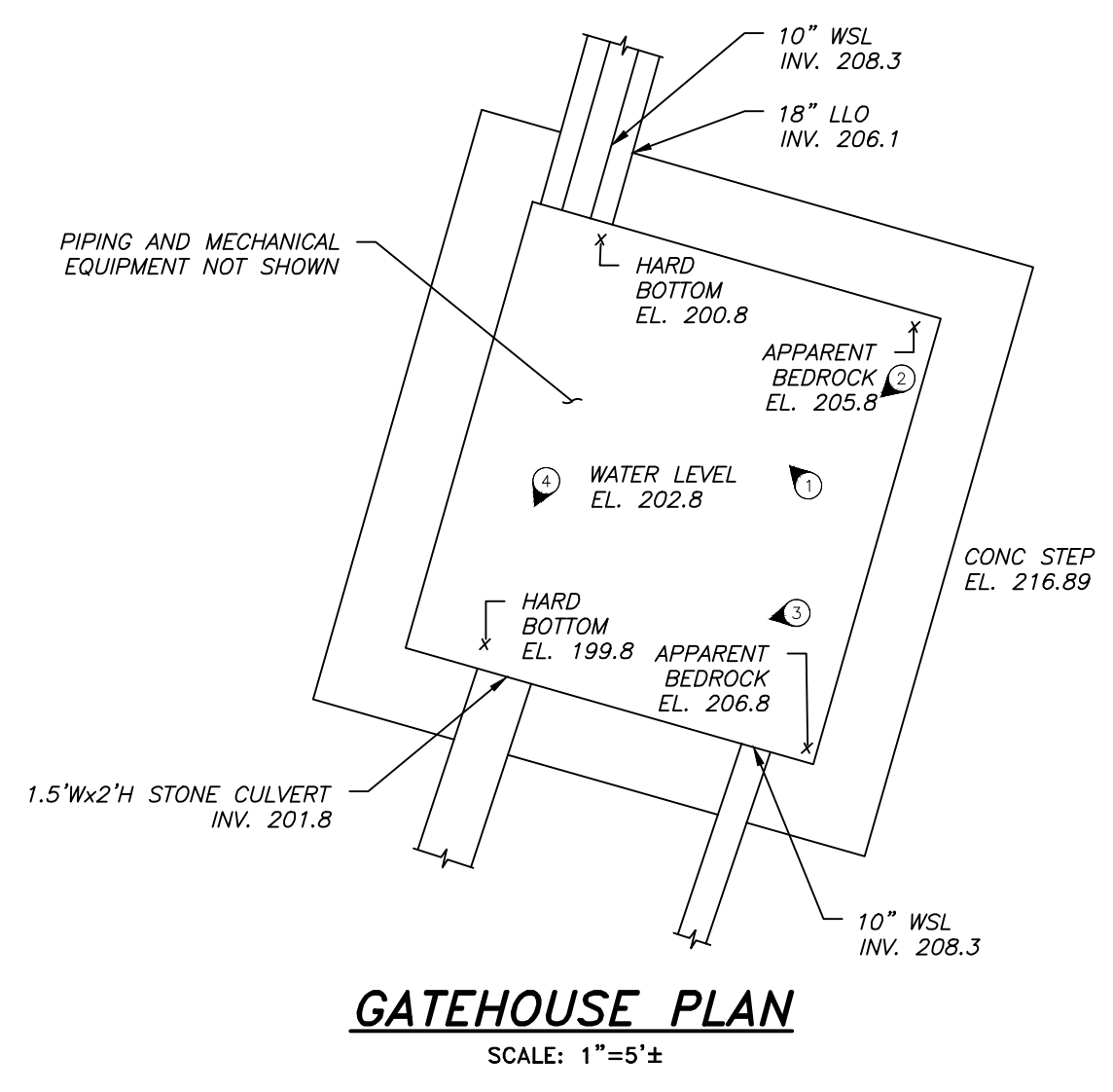

**GATEHOUSE PLAN**  
 SCALE: 1"=5'±



**PHOTO 1**



**PHOTO 2**



**PHOTO 3**



**PHOTO 4**

**PUMP HOUSE PHOTOS**

REVISIONS:	

PROJECT NO.:	19167.02
DATE:	NOVEMBER 2022
SCALE:	AS NOTED
DESIGNED BY:	MLP
CHECKED BY:	MED
DRAWN BY:	LMC
APPROVED BY:	ARO

EXISTING CONDITIONS  
 SECTIONS & DETAILS

SHEET NO.: **2.2**

P:\WORK\19\_000\19167.02 - Wayland - Snakebrook Dam Rehabilitation - MA\DWG\1.1 - EXIST. CONDITIONS PLAN.dwg  
 PLOT DATE: 11/15/2022 10:58:11 AM



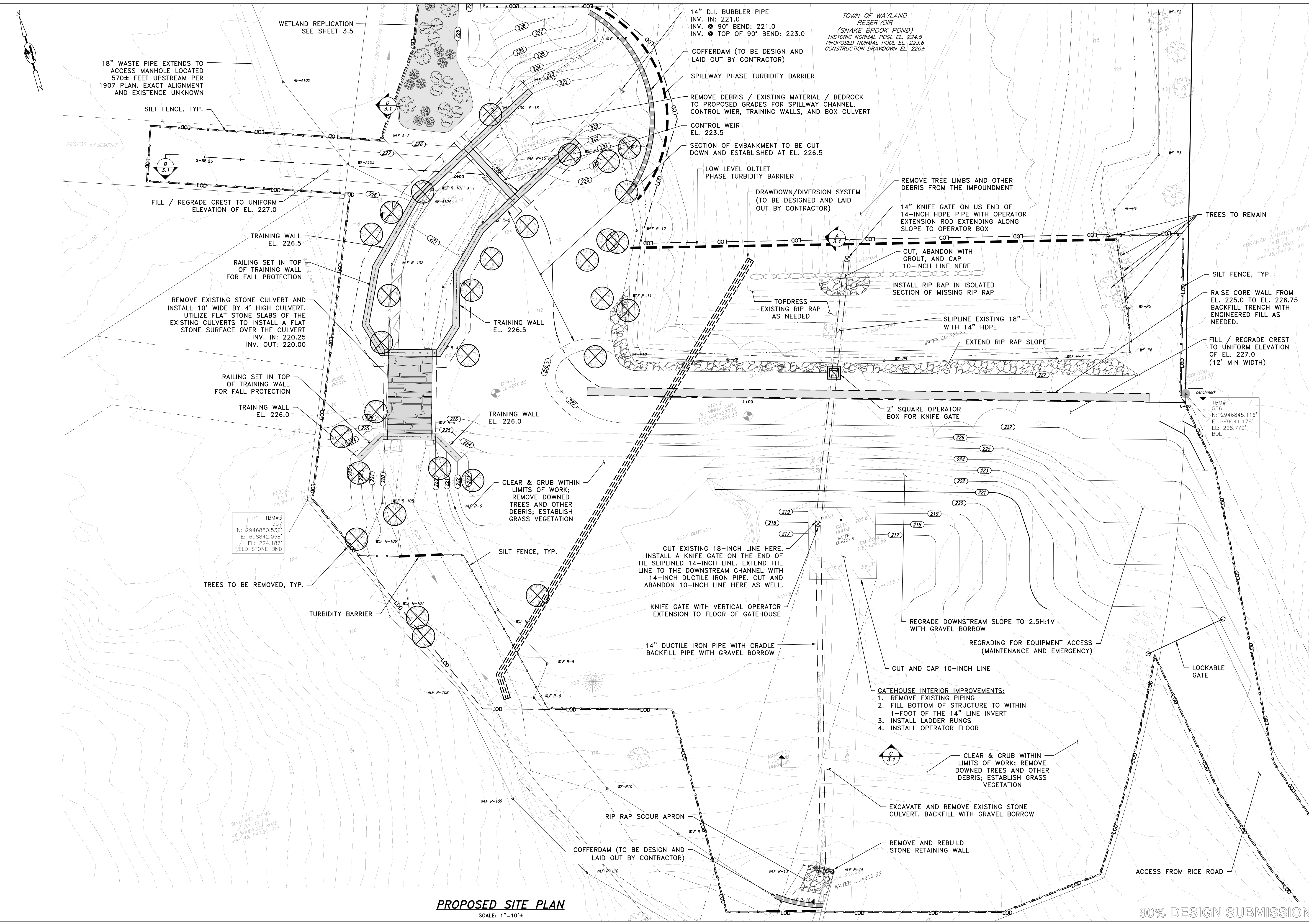

**PROPOSED SITE PLAN**  
SCALE: 1"=10'±

90% DESIGN SUBMISSION



SCALE ADJUSTMENT GUIDE  
0" 1"  
BAR IS ONE INCH ON ORIGINAL DRAWING.

**SNAKE BROOK DAM REHABILITATION**  
MA01119  
WAYLAND, MASSACHUSETTS  
TOWN OF WAYLAND CONSERVATION COMMISSION

REVISIONS:

NO.	DESCRIPTION

PROJECT NO.: 19167.02  
DATE: NOVEMBER 2022  
SCALE: AS NOTED  
DESIGNED BY: MLP  
CHECKED BY: MED  
DRAWN BY: LMC  
APPROVED BY: ARO

PROPOSED SITE PLAN

SHEET NO.: 3.0













SCALE ADJUSTMENT GUIDE  
 0" 1"  
 BAR IS ONE INCH ON ORIGINAL DRAWING.

**SNAKE BROOK DAM REHABILITATION**  
 MA01119  
 WAYLAND, MASSACHUSETTS  
 TOWN OF WAYLAND CONSERVATION COMMISSION

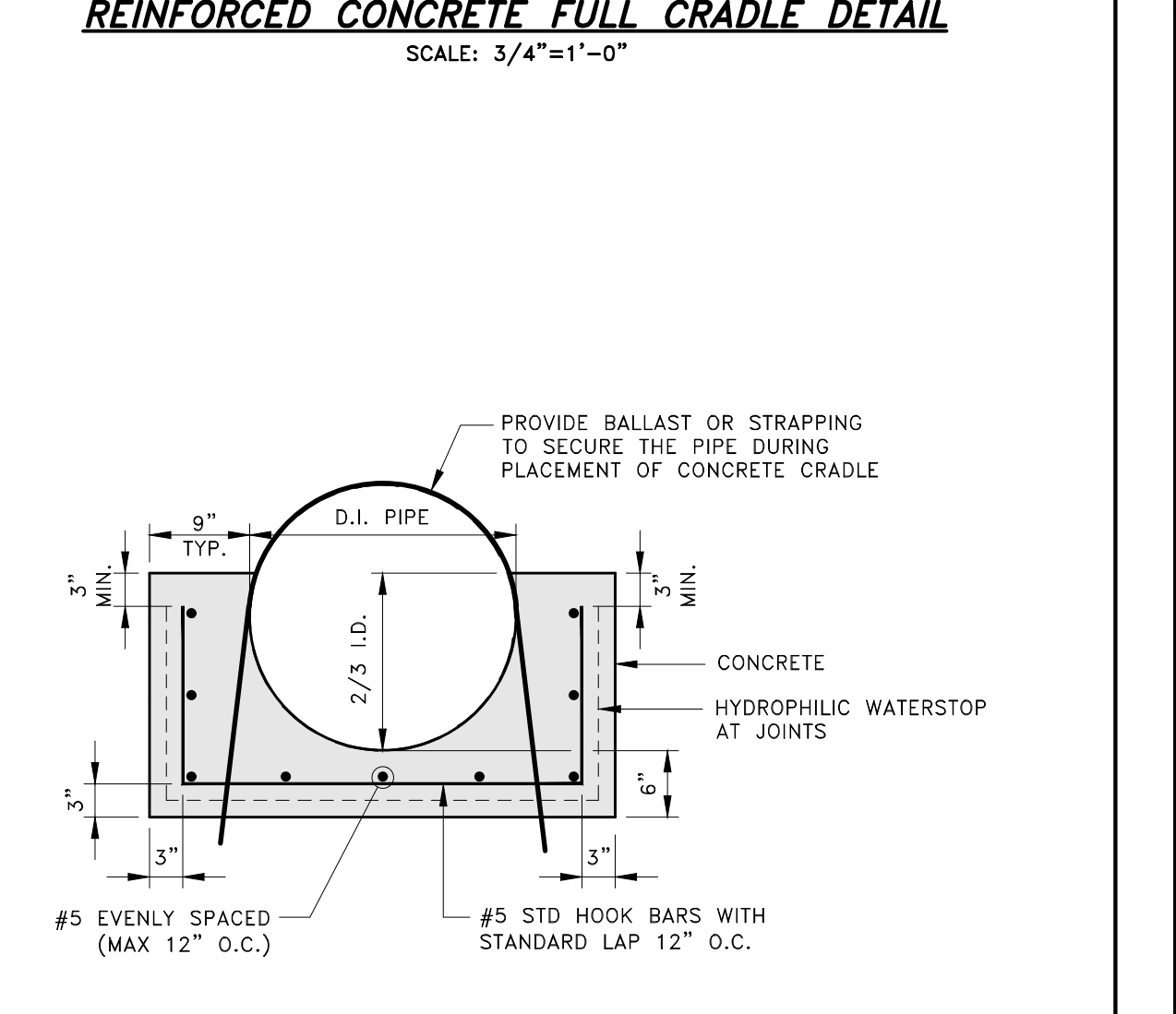
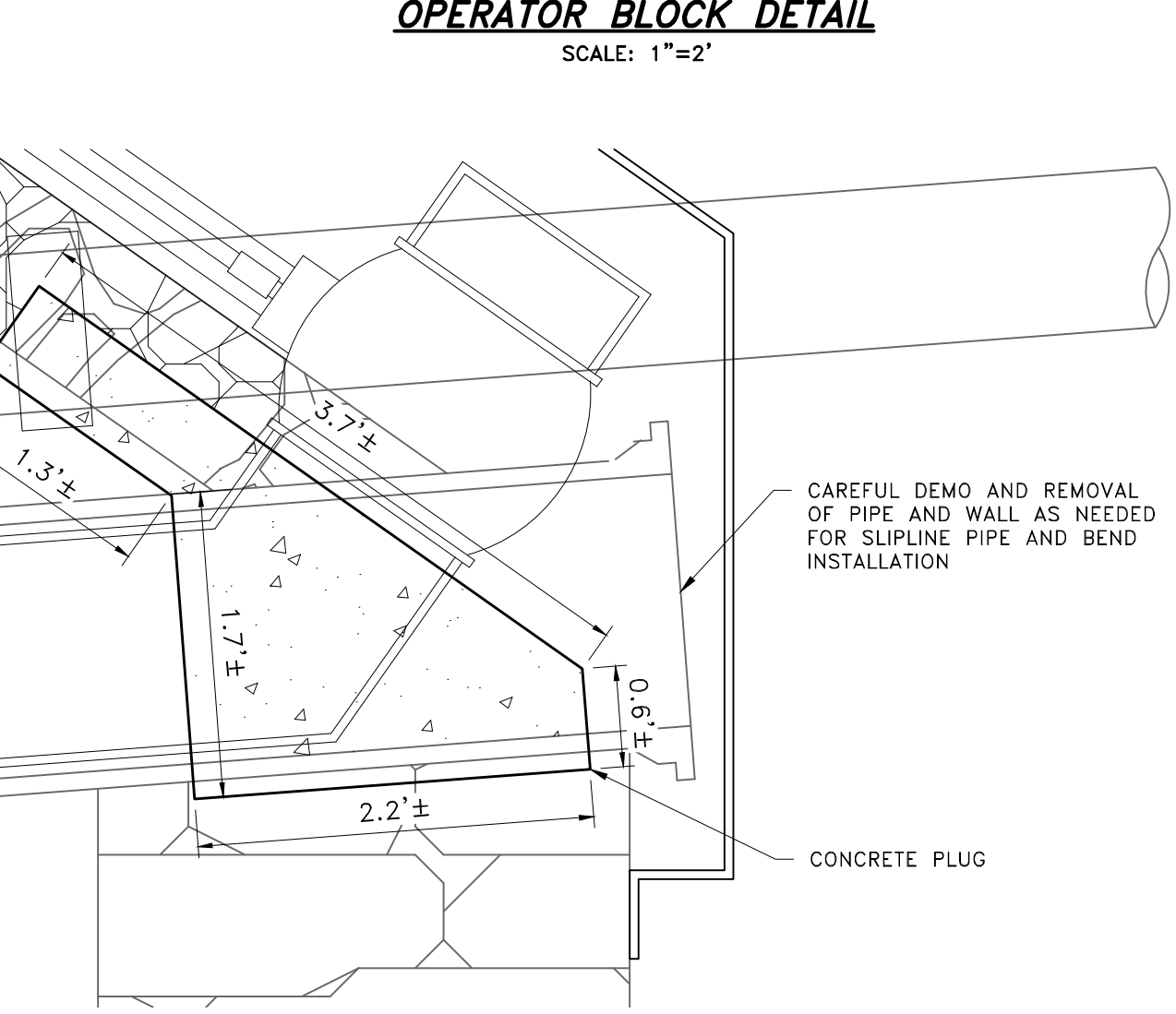
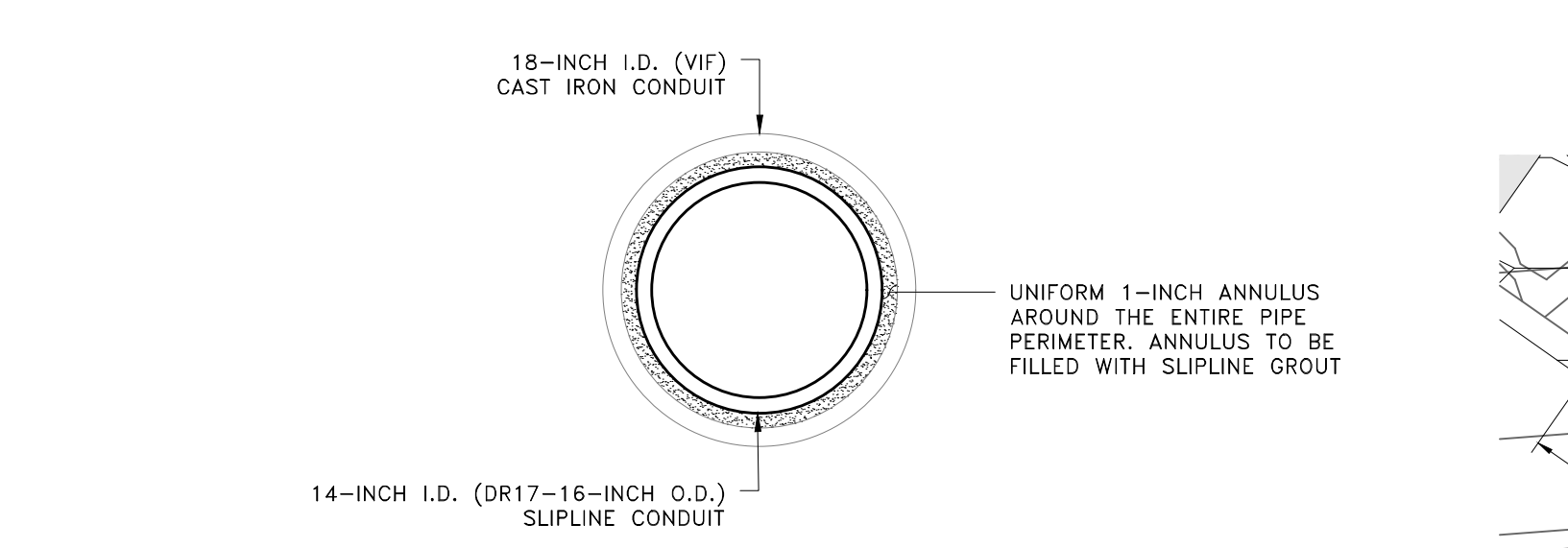
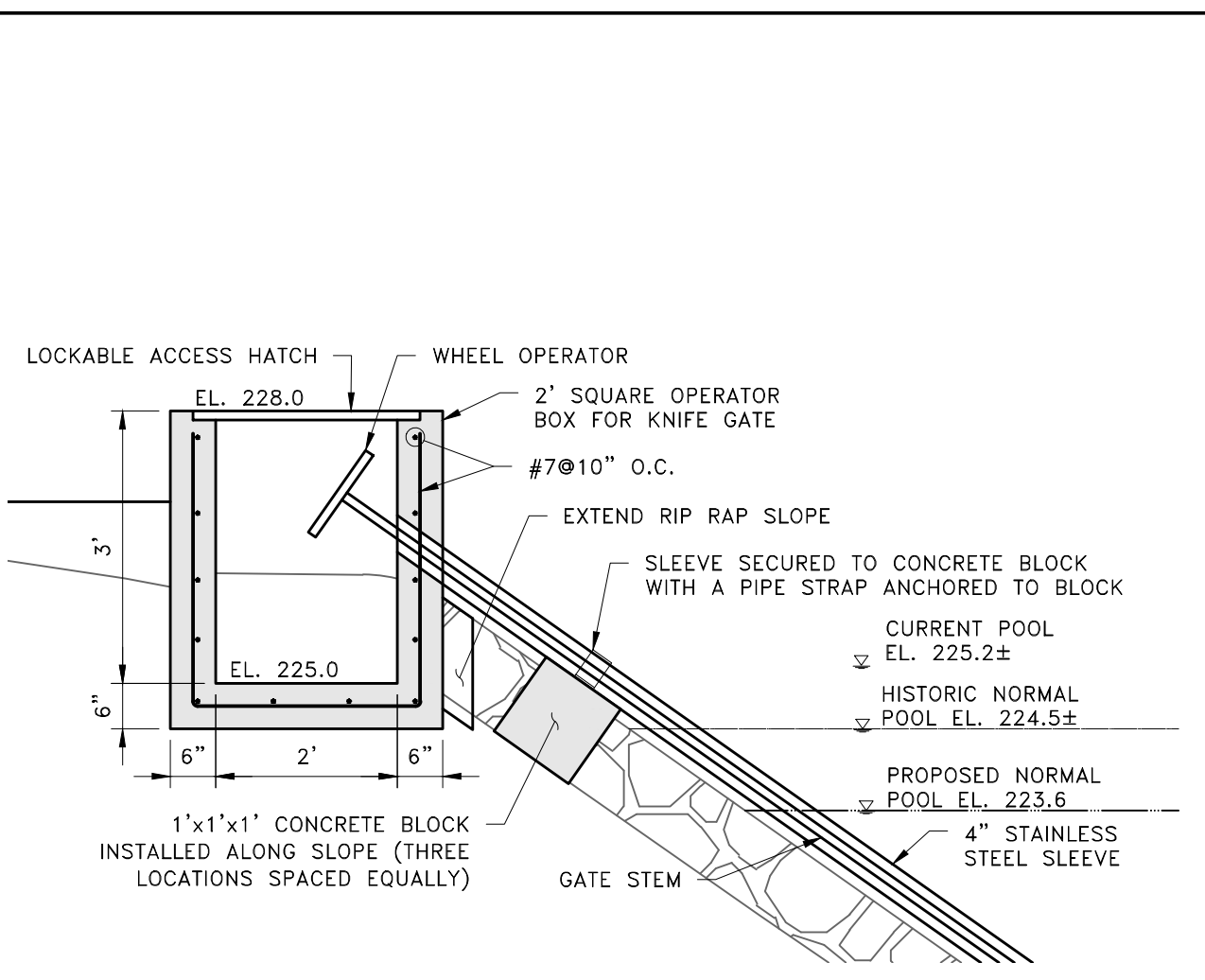
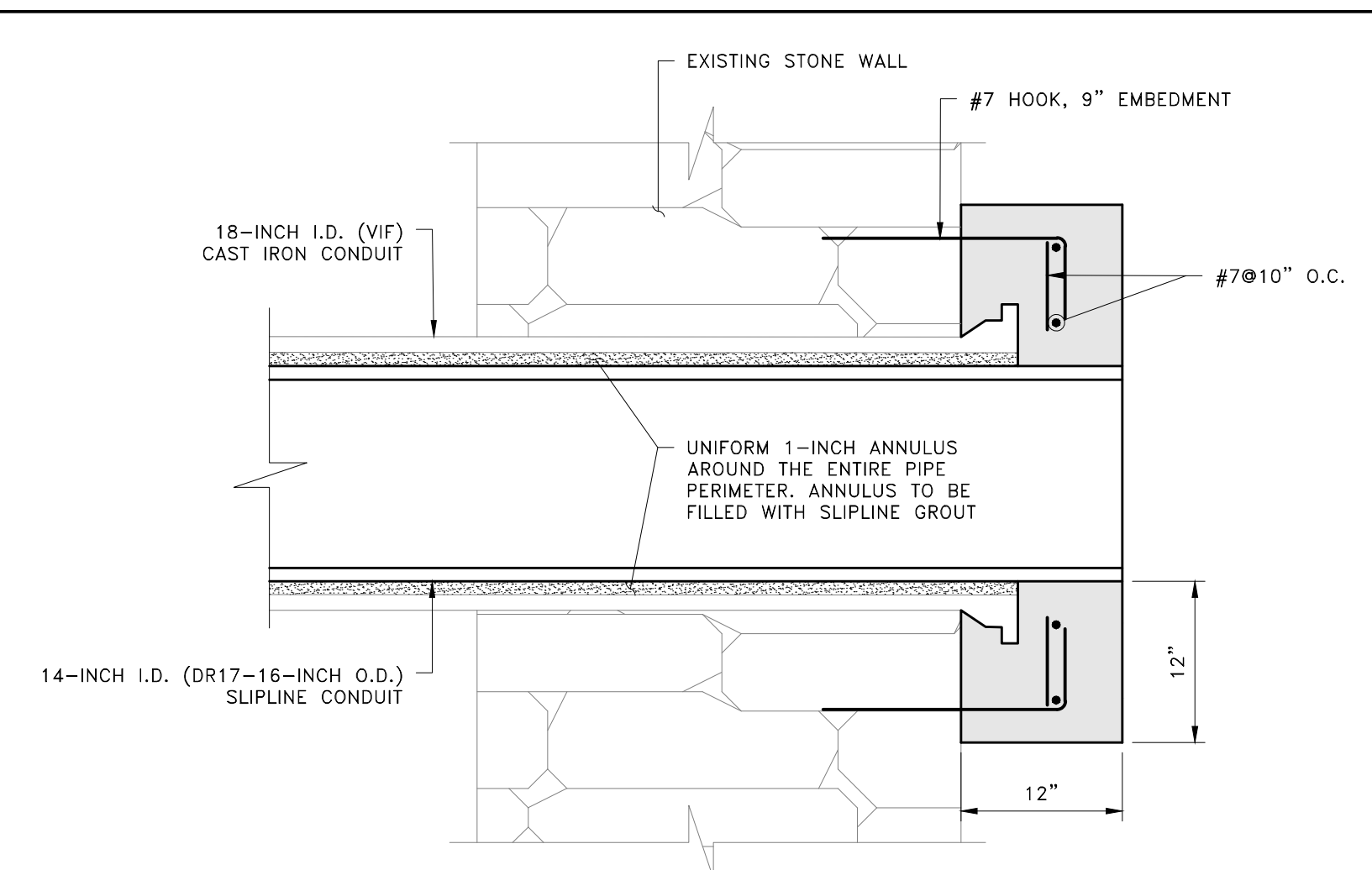
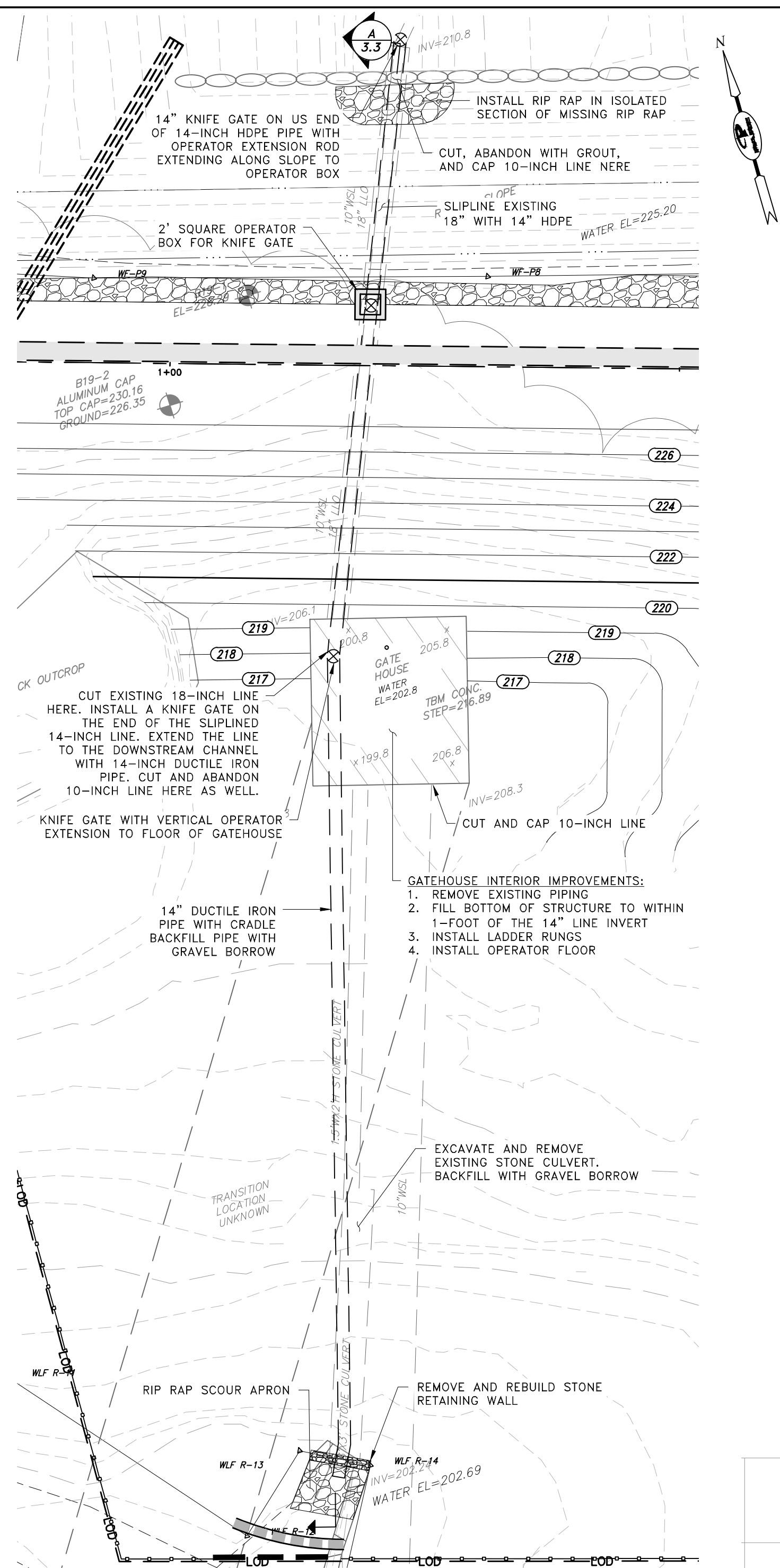

- SLIPLINE NOTES:**
- PREPARATION**
1. VERIFY THE INSIDE DIAMETER AND CONDITION OF THE 18-INCH CAST IRON HOST CONDUIT. ADJUST APPROACH AS NEEDED.
  2. CLEAN THE HOST CONDUIT OF ALL DEBRIS.
- PIPE INSTALLATION**
1. INSTALL THE 14-INCH SLIPLINE CONDUIT. PIPE JOINTING SHALL COMPLY WITH PIPE MANUFACTURER'S RECOMMENDATIONS. PROVIDE ADDITIONAL MEASURES AS NECESSARY TO ENSURE THE SLIPLINE PIPE IS INSTALLED IN SUCH A WAY SO THAT A UNIFORM ANNULUS IS PROVIDED AROUND THE ENTIRE PIPE PERIMETER.
- GROUT INSTALLATION**
1. INSTALL GROUT LINES, VENT PORTS, AND BULKHEADS AS NECESSARY FOR THE GROUTING OPERATIONS. INCORPORATE MEASURES TO ALLOW FOR THE VERIFICATION OF COMPLETE ANNULUS GROUTING.
  2. GROUT THE ANNULUS AT AN APPROPRIATE PRESSURE TO FILL THE ANNULUS AND NOT CAUSE DAMAGE TO THE HOST OF SLIPLINE CONDUIT. MEASURE GROUT TAKE AND COMPARE TO EXPECTED TAKE AND CONFIRM.
  3. INSTALL A REINFORCED CONCRETE CAP AT BOTH ENDS OF THE SLIPLINED SECTION OF PIPE.

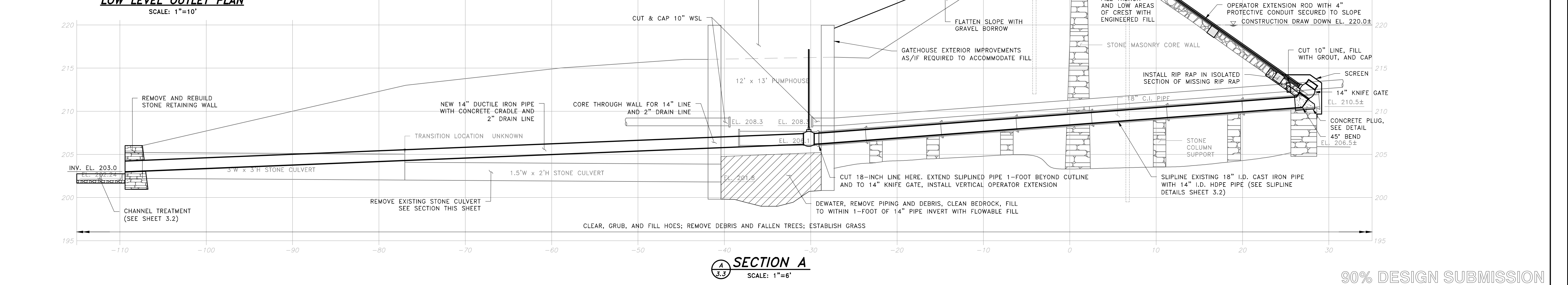

REVISIONS:

NO.	DESCRIPTION

PROJECT NO.: 19167.02  
 DATE: NOVEMBER 2022  
 SCALE: AS NOTED  
 DESIGNED BY: MLP  
 CHECKED BY: MED  
 DRAWN BY: LMC  
 APPROVED BY: ARO

LOW LEVEL OUTLET SECTIONS AND DETAILS  
 SHEET NO.: 3.3







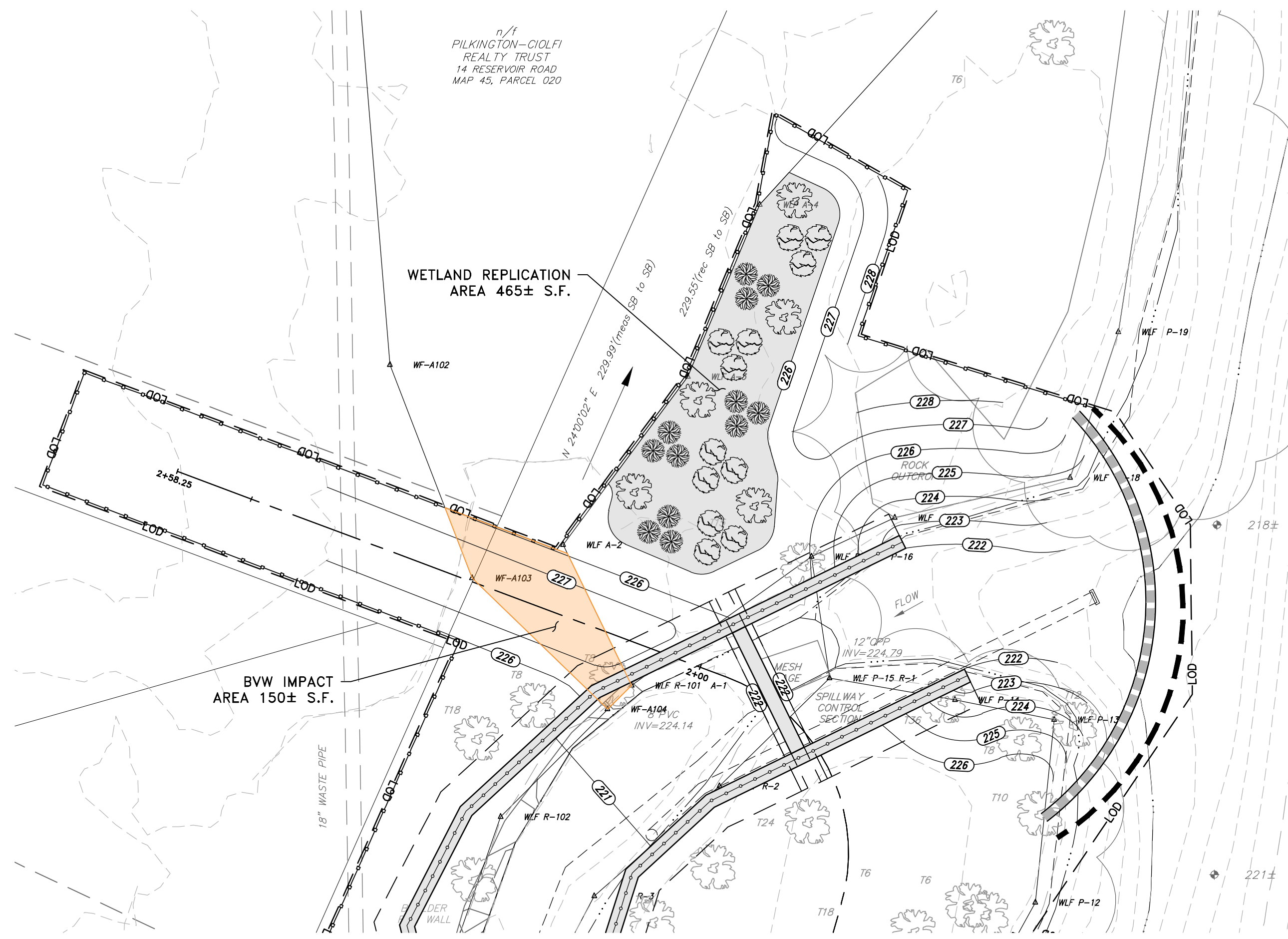

**PLANTING TABLE**

SYMBOL	COMMON NAME	SCIENTIFIC NAME	SIZE	QUANTITY	SPACING
	RED MAPLE	ACER RUBRUM	4' MIN.	5	12' O.C. ±
	SWEET PEPPERBUSH	CLETHRA ALNIFOLIA	1-3'	12	CLUSTERS OF 3 (6'-8' O.C.)
	HIGHBRUSH BLUEBERRY	VACCINIUM CORYMBOSUM	1-3'	12	CLUSTERS OF 3 (6'-8' O.C.)
	WETLAND SEED MIX**	---	---	---	THROUGHOUT

\*\* NEW ENGLAND WETLAND PLANTS WETMIX OR APPROVED EQUIVALENT.

**WETLAND REPLICATION NOTES**

- APPROXIMATELY 150 SQUARE FEET OF BORDERING VEGETATED WETLANDS WILL BE PERMANENTLY ALTERED IN THIS PROJECT. APPROXIMATELY 465 SQUARE FEET SHALL BE REPLICATED ON-SITE, AS SHOWN ON THE WETLAND REPLICATION PLAN. THIS WILL PROVIDE A REPLACEMENT RATIO OF APPROXIMATELY 3:1.
- THE CONTRACTOR SHALL STAKE OUT THE FOLLOWING AREAS AS INDICATED ON THE WETLAND REPLICATION PLAN:
  - EROSION CONTROL/LIMIT OF WORK
  - REPLICATION AREA
- EROSION CONTROL SHALL BE INSTALLED IN ACCORDANCE WITH THE CONTRACT PLANS AND DOCUMENTS. SEE EROSION AND SEDIMENT CONTROL NOTES.
- ALL STAGES OF CONSTRUCTION SHALL BE OBSERVED BY A WETLAND SPECIALIST.
- FALLEN TREES AND UNDERSTORY VEGETATION WITHIN THE REPLICATION AREA SHALL BE REMOVED. EXISTING TREES MAY BE SELECTED TO REMAIN ON HUMMOCKS IF APPROPRIATE. SELECT INORGANIC MATERIALS SUCH AS ROCKS AND BOULDERS AND SELECT TREES AND LOGS MAY BE STOCKPILED FOR USE IN THE REPLICATION AREA TO PROVIDE WILDLIFE HABITAT.
- EXCAVATE TO APPROPRIATE SUBGRADES APPROXIMATELY 12 INCHES BELOW ELEVATION OF ADJOINING WETLAND EDGE. MATERIAL SHALL BE SPREAD TO CREATE A MOUND AND POOL TOPOGRAPHY FOR THE FINAL GRADE.
- THE WETLAND SPECIALIST SHALL CONFIRM THE ELEVATIONS OF THE REPLICATION AREA PRIOR TO PLACEMENT OF ORGANIC TOPSOIL.
- ORGANIC TOPSOIL SHALL BE IMPORTED IN A SUFFICIENT VOLUME TO COVER THE REPLICATION AREA TO AN AVERAGE DEPTH OF 12 INCHES. TOPSOIL SHALL CONSIST OF A 50/50 MIX OF LOAM AND ORGANIC MATERIAL.
- THE REPLICATION AREA SHALL BE PLANTED WITH INDIGENOUS PLANTS SPECIFIED IN THE PLANTING TABLE. SAPLINGS SHALL BE PLACED 12 FEET ON CENTER AT UPPER PERIMETER AND ALONG SURROUNDING SLOPES. SHRUBS WILL BE ARRANGED IN CLUSTERS OF 3 STAGGERED AT AN AVERAGE SPACING OF 6-8' ON CENTER. PLANTS SHALL BE PLANTED IN A RANDOM ARRANGEMENT TO MIMIC THE NATURAL SURROUNDINGS. FOLLOWING INSTALLATION OF PLANTINGS, A NEW ENGLAND WETLAND SEED MIX SHALL BE ADDED TO PROVIDE HERBACEOUS COVER.
- INORGANIC MATERIALS AND SAVED TREES/LOGS SHALL BE SCATTERED THROUGHOUT THE REPLICATION AREA TO COVER APPROXIMATELY 20% OF THE SURFACE AREA.
- IMMEDIATELY FOLLOWING THE PLANTING OF THE REPLICATION AREA, A SECOND ROW OF EROSION CONTROL SHALL BE INSTALLED BETWEEN THE NEW REPLICATION AREA AND THE UPLAND AREA AS INDICATED ON THE WETLAND REPLICATION PLAN. THIS SHEET, SLOPES BORDERING THE AREA SHALL BE STABILIZED WITH LOAM AND SEED.
- THE REPLICATION AREA SHALL BE VEGETATIVELY STABILIZED BY AT LEAST 75% WITHIN TWO GROWING SEASONS. ALL REPLICATION TASKS SHALL BE DONE IN ACCORDANCE WITH THE WETLAND PROTECTION ACT AND REGULATIONS UNDER 310CMR 10.55 AND THE MASSACHUSETTS INLAND WETLAND REPLICATION GUIDE. EROSION CONTROL BETWEEN THE EXISTING WETLAND AND THE CREATED WETLAND SHALL BE REMOVED ONCE THE 75% STABILIZATION RATE HAS OCCURRED AND HAS BEEN VERIFIED BY THE CONSERVATION COMMISSION.
- PROPOSED GRADES SHOWN ARE APPROXIMATE AND FIELD CONDITIONS ARE TO BE USED IN DETERMINING APPROXIMATE FINISH GRADES.

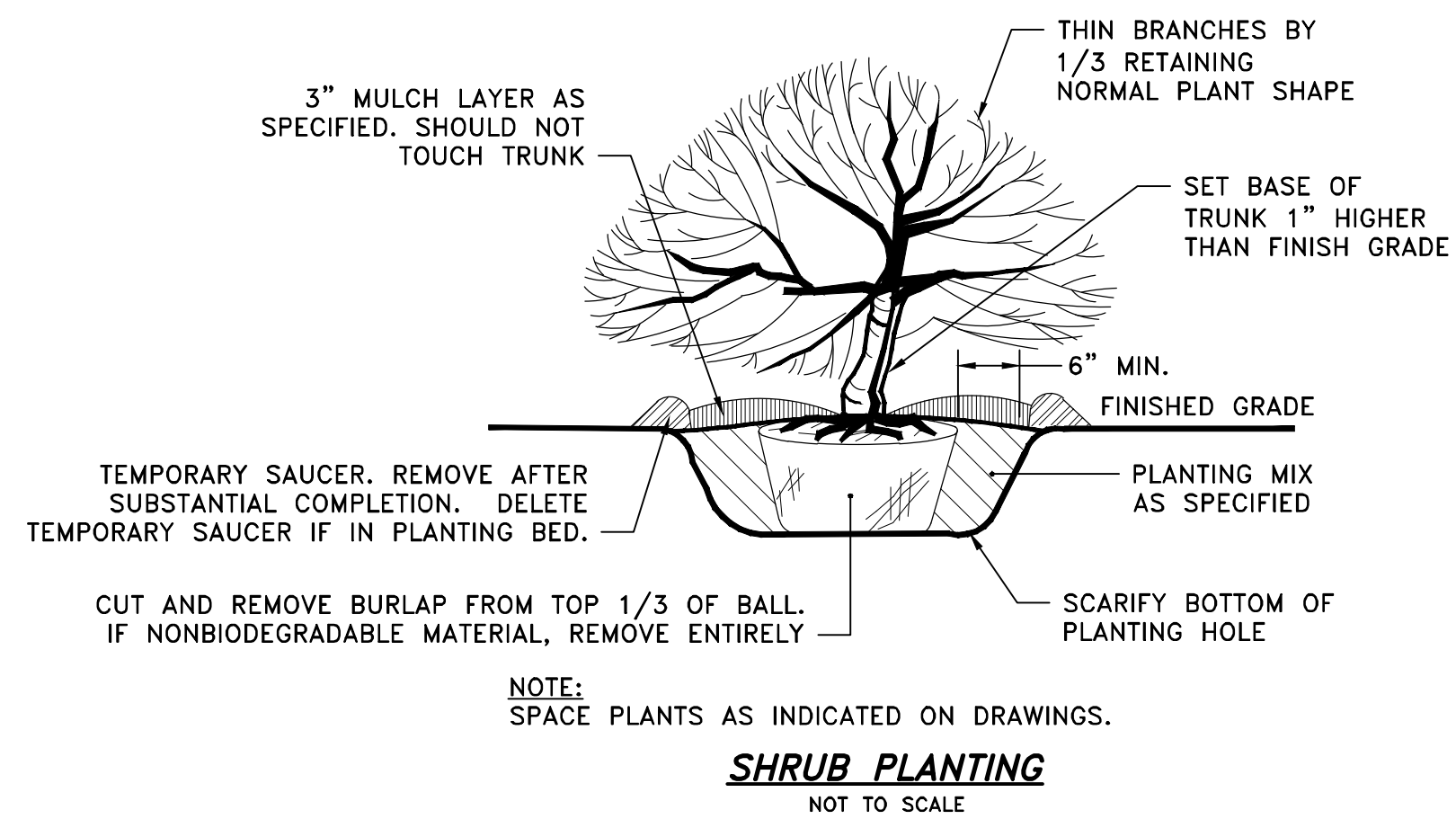
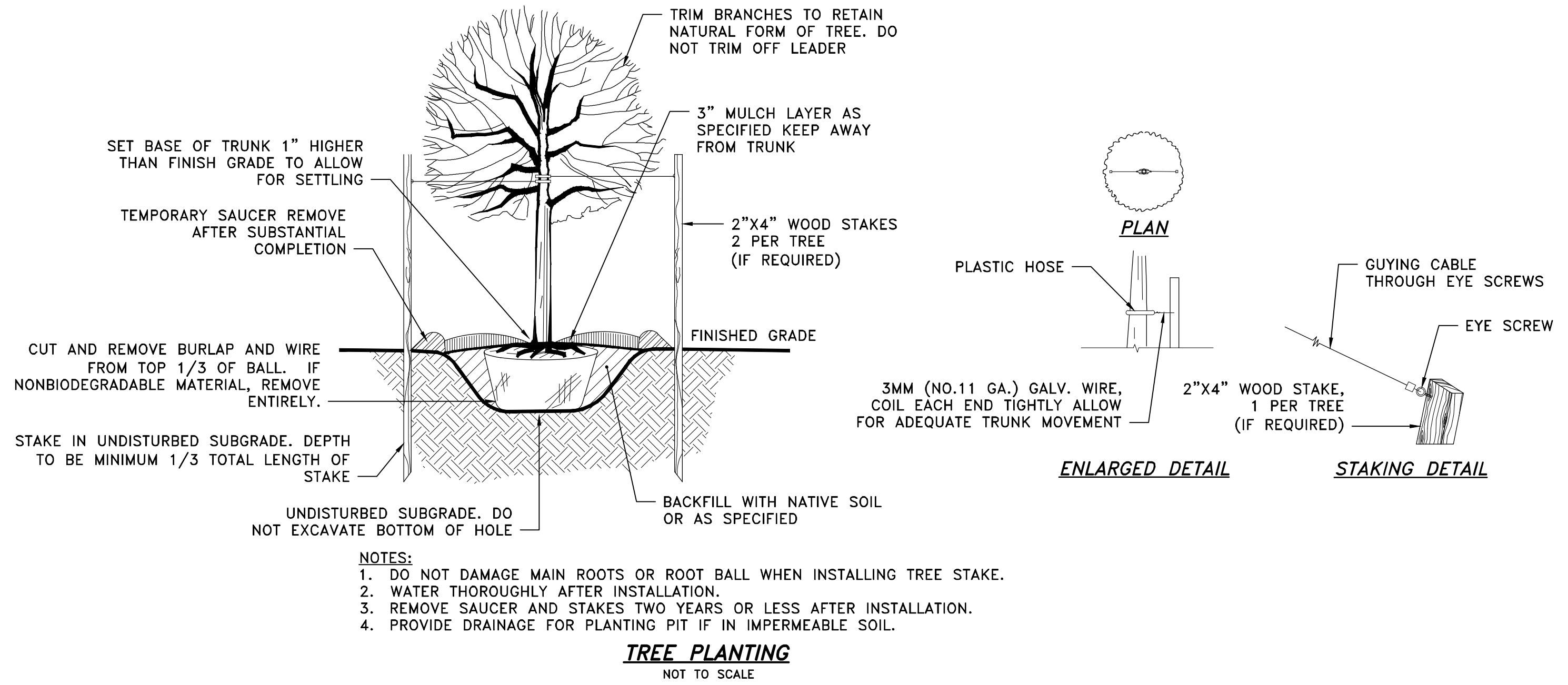
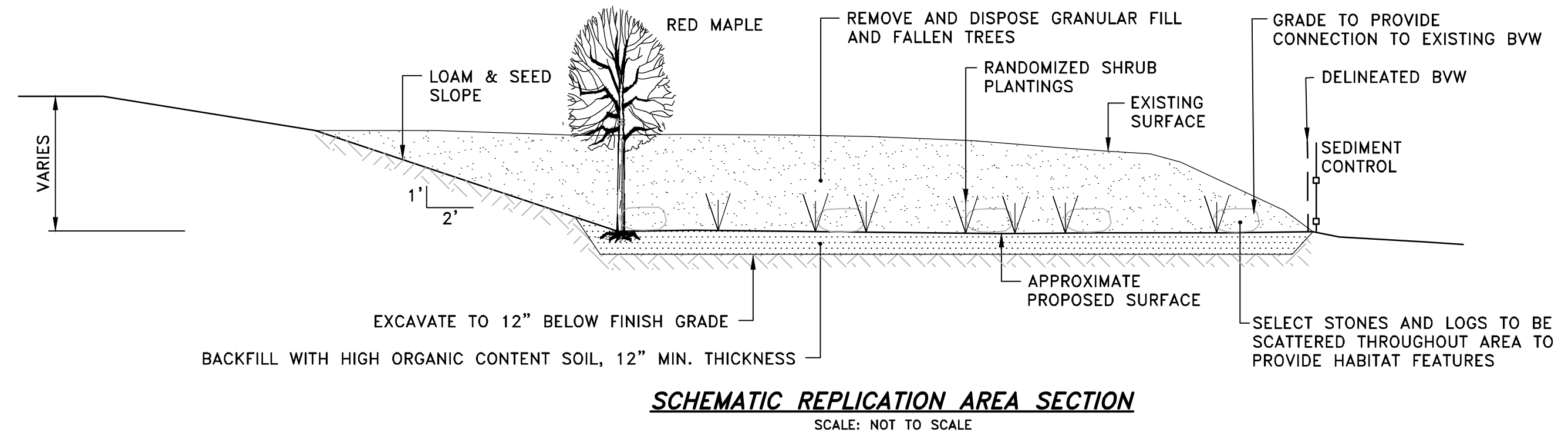

SCALE ADJUSTMENT GUIDE  
0" 1"  
BAR IS ONE INCH ON ORIGINAL DRAWING.

**SNAKE BROOK DAM REHABILITATION**  
MA01119  
WAYLAND, MASSACHUSETTS  
TOWN OF WAYLAND CONSERVATION COMMISSION

REVISIONS:

RTC	SEPTEMBER 2021
RTC	OCTOBER 2021

PROJECT NO.: 19167.02  
DATE: NOVEMBER 2022  
SCALE: AS NOTED  
DESIGNED BY: MLP  
CHECKED BY: MED  
DRAWN BY: LMC  
APPROVED BY: ARO

WETLAND REPLICATION PLAN  
SHEET NO.: 3.5



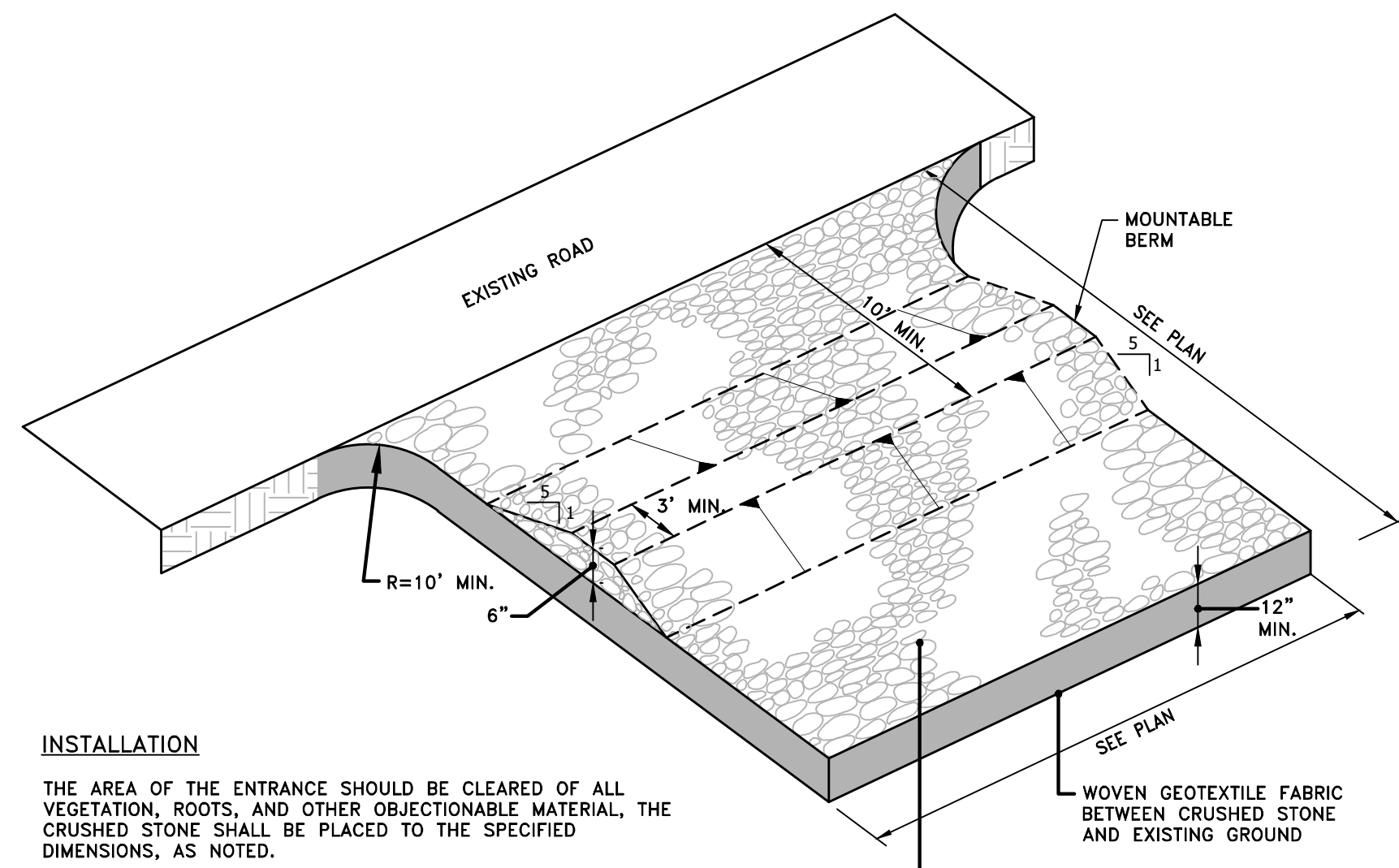

**INSTALLATION**

THE AREA OF THE ENTRANCE SHOULD BE CLEARED OF ALL VEGETATION, ROOTS, AND OTHER OBJECTIONABLE MATERIAL, THE CRUSHED STONE SHALL BE PLACED TO THE SPECIFIED DIMENSIONS, AS NOTED.

**MAINTENANCE**

THE ENTRANCE SHALL BE MAINTAINED IN A CONDITION WHICH WILL PREVENT TRACKING OR FLOWING OF SEDIMENTS ONTO PUBLIC RIGHT-OF-WAYS THIS WILL REQUIRE PERIODIC TOP DRESSING WITH ADDITIONAL STONE, OR ADDITIONAL LENGTH, AS CONDITIONS DEMAND, AND REPAIR, AND / OR CLEANOUT OF ANY MEASURES USED TO TRAP SEDIMENT. ALL SEDIMENT SPILLED, DROPPED, WASHED OR TRACKED ONTO PUBLIC RIGHT-OF-WAYS MUST BE REMOVED IMMEDIATELY.

**LOCATION**

SEE PROJECT PLANS FOR LOCATION OF CONSTRUCTION ENTRANCE.

**CONSTRUCTION ENTRANCE PROTECTION STONE STABILIZATION PAD**

NOT TO SCALE

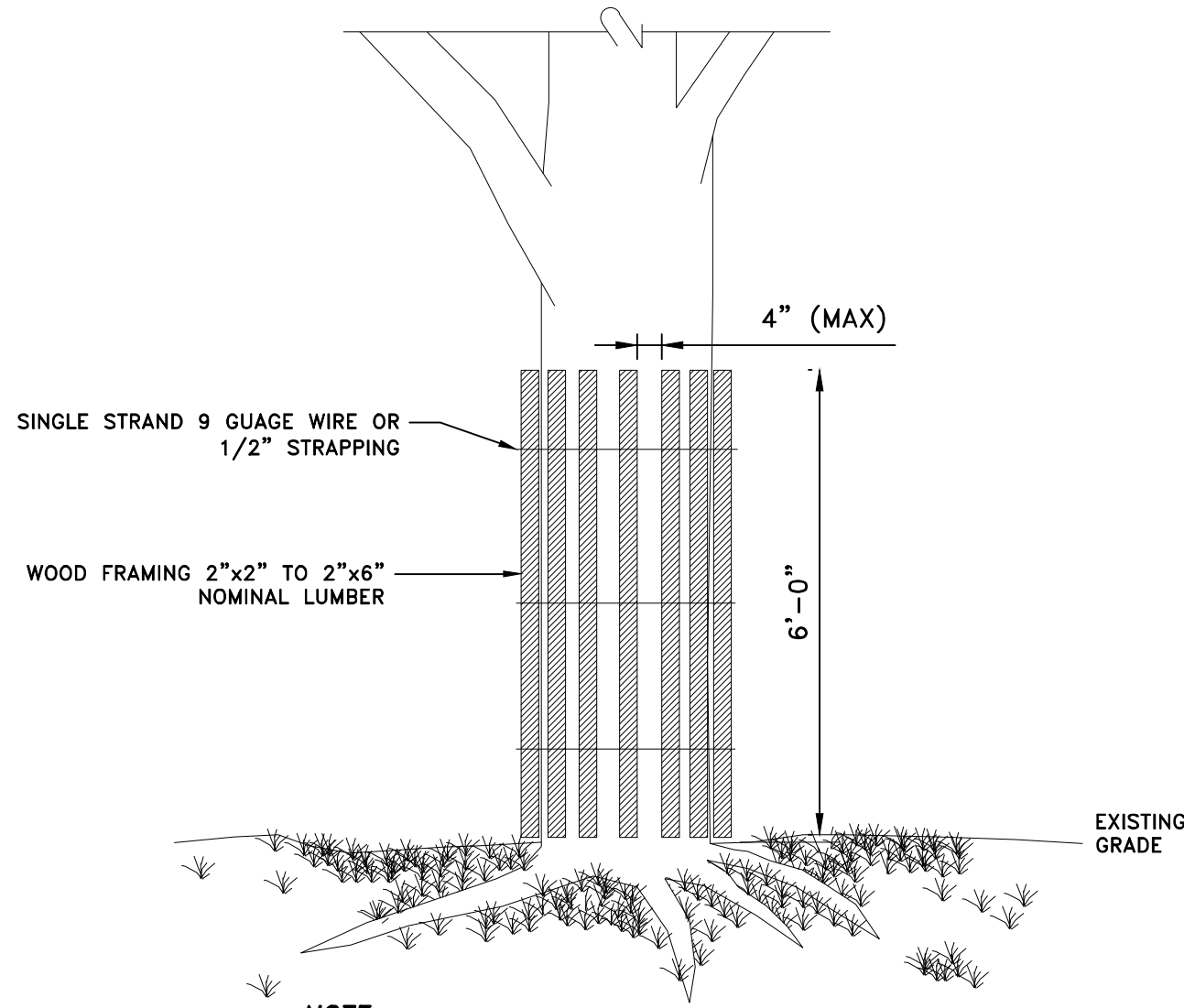

**NOTE:** THIS DETAIL SHALL BE USED TO PROTECT THE TREE'S TRUNK IN SITUATIONS WHERE CONSTRUCTION IS IN CLOSE PROXIMITY.

**TREE PROTECTION DEVICE**

NOT TO SCALE

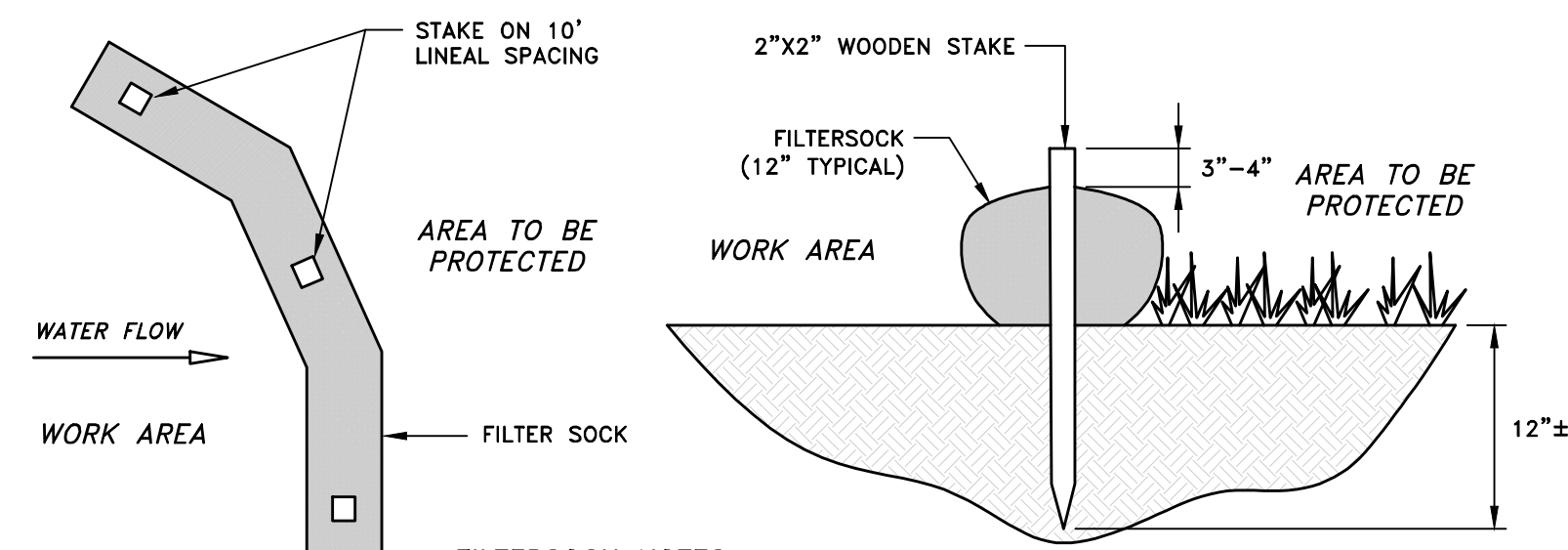

**FILTER SOCK NOTES:**

1. COMPOST / SOIL / ROCK / SEED FILL TO MEET APPLICATION REQUIREMENTS.
2. COMPOST MATERIAL TO BE REMOVED OR DISPERSED ON SITE AS DETERMINED BY ENGINEER.

**FILTER SOCK DETAIL**

NOT TO SCALE

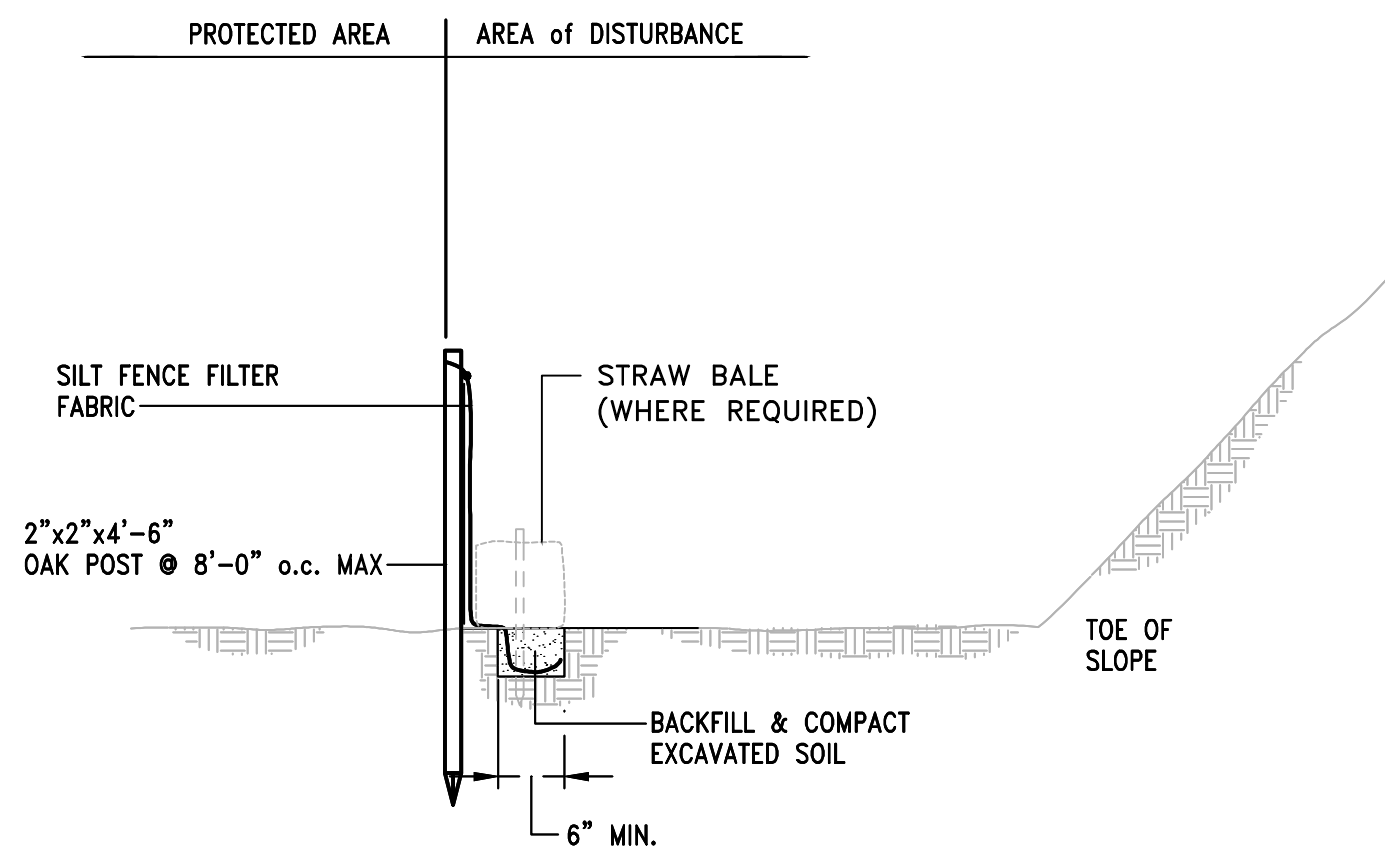

**NOTE:**

SILT FENCE FABRIC SHALL NOT BE SLIT. STRAW BALE POST SHALL BE DRIVEN THROUGH SILT FENCE FABRIC.

**SILT FENCE DETAIL**

NOT TO SCALE

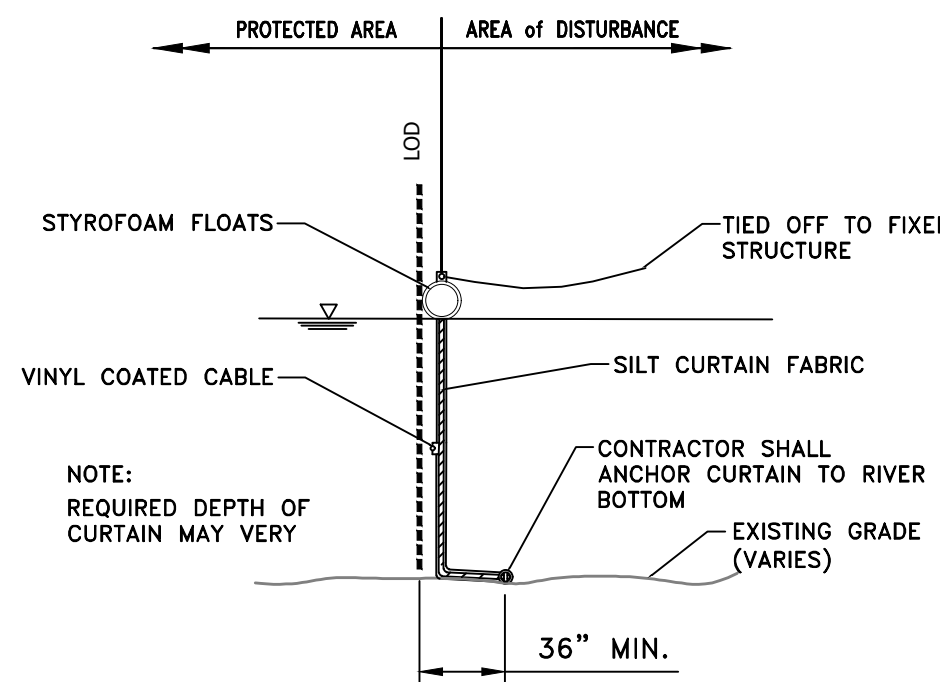

**TYPICAL TURBIDITY BARRIER**

NOT TO SCALE

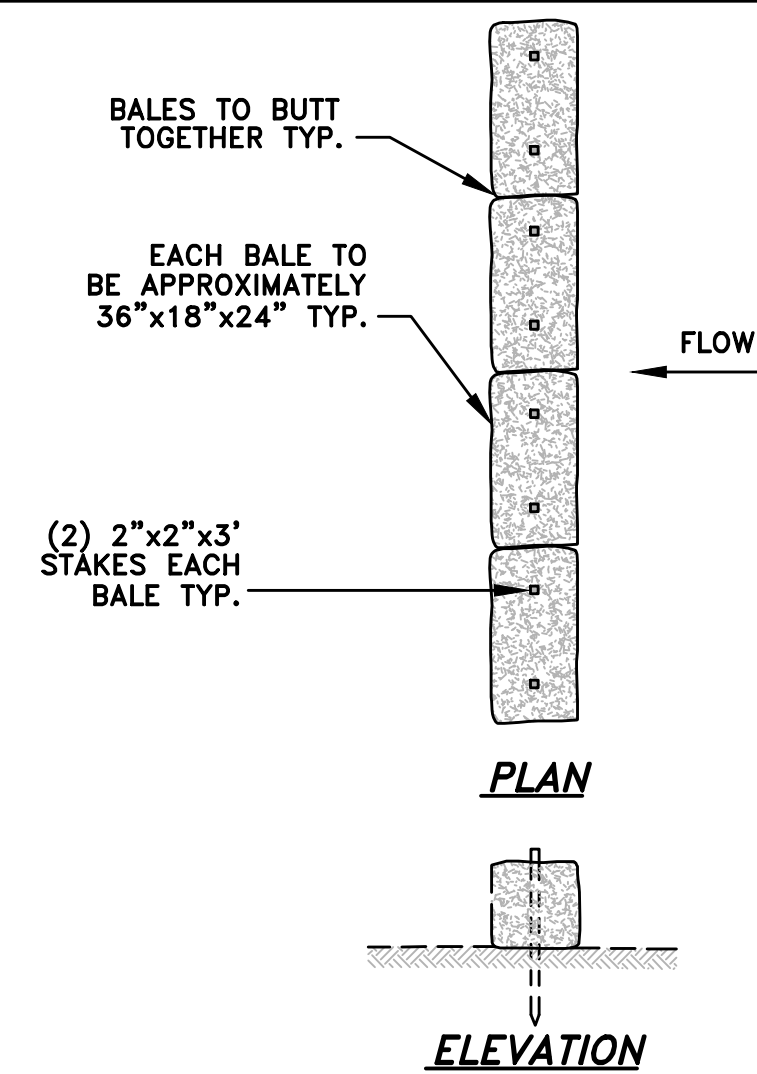

**STRAW BALE DETAIL**

NOT TO SCALE

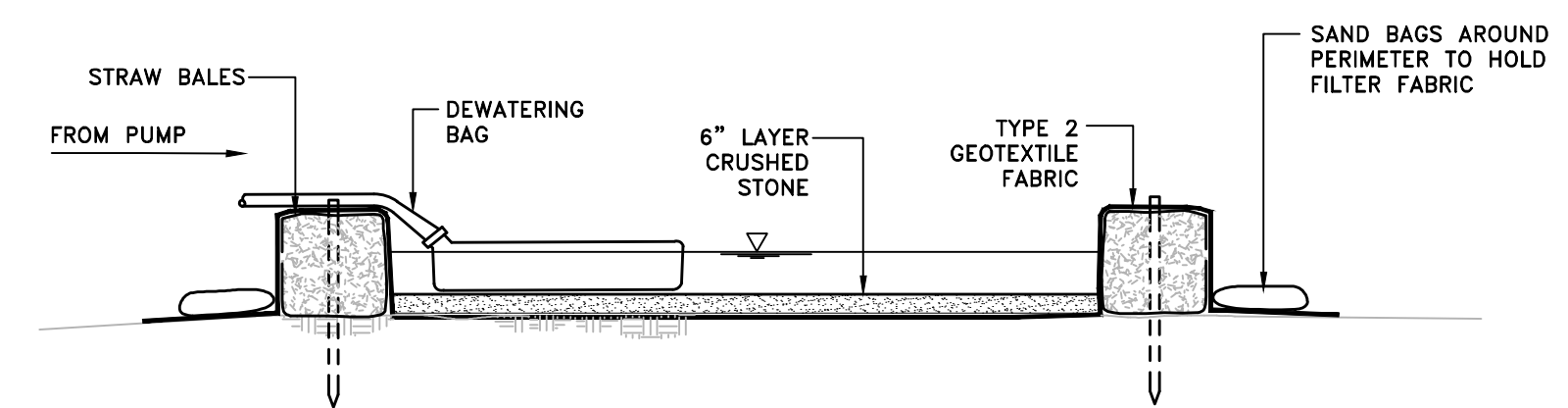

**NOTE:** CONTRACTOR TO PERIODICALLY REMOVE SILT AND STONE AT TRENCH DRAIN TO PROMOTE FLOW OF WATER FROM BASIN. ALTERNATIVELY AN OUTFLOW WEIR MAY BE SUBMITTED FOR APPROVAL.

**FILTER FABRIC DEWATERING BASIN**

NOT TO SCALE

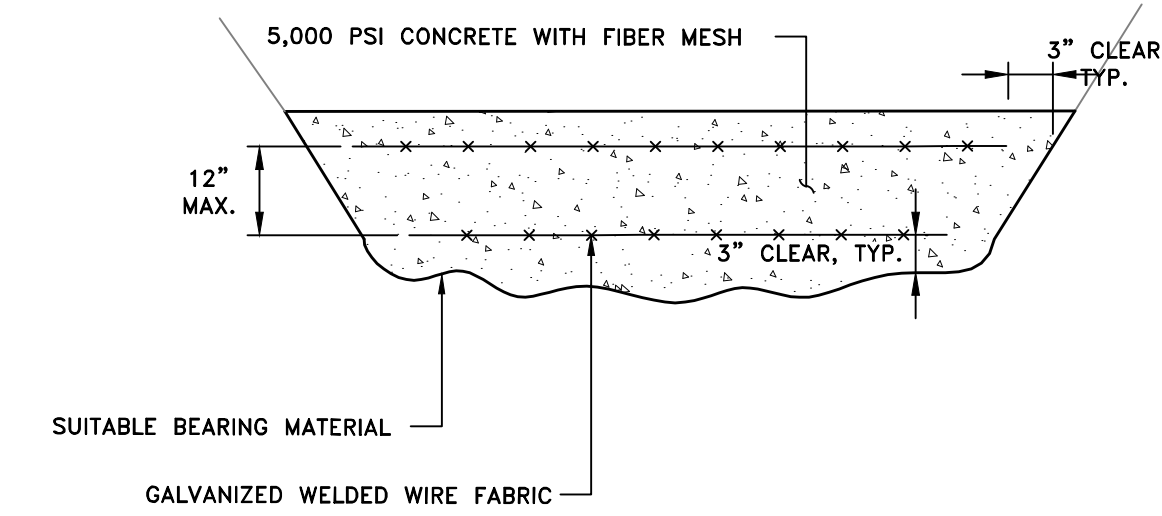

**MASS CONCRETE DETAIL**

NOT TO SCALE

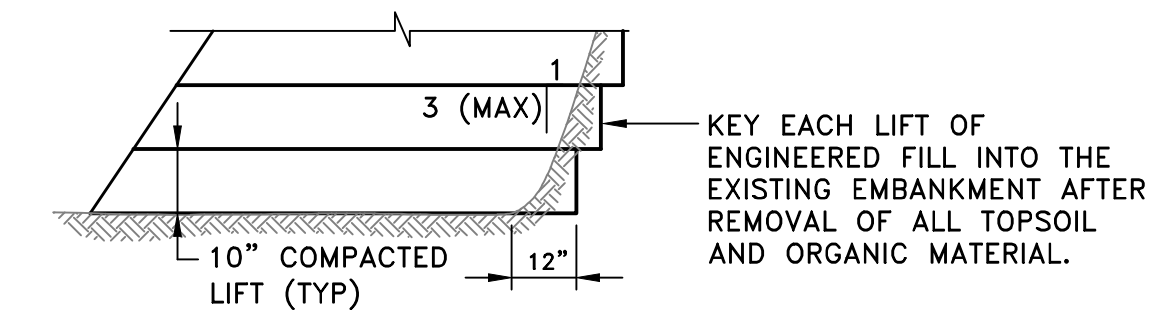

**PLACEMENT OF FILL MATERIALS**

NOT TO SCALE

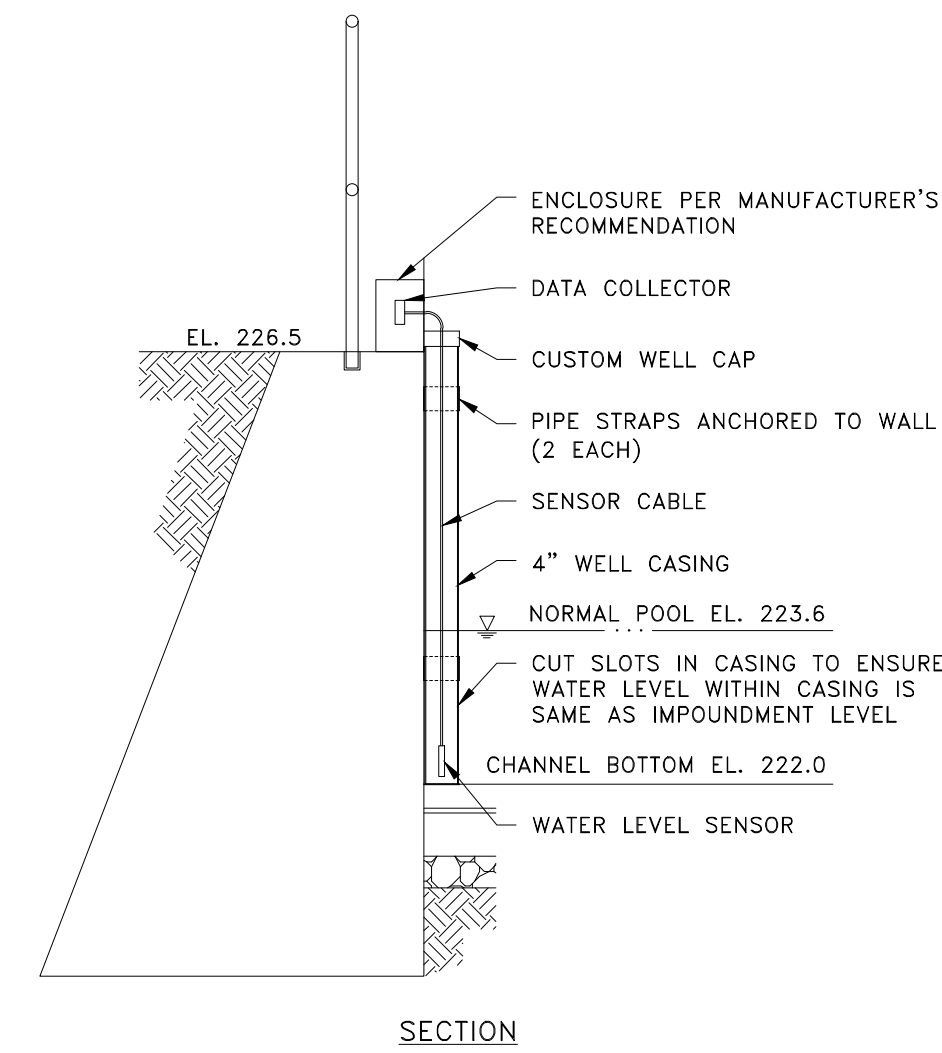

**WATER LEVEL METER**

SCALE: 1"=2'

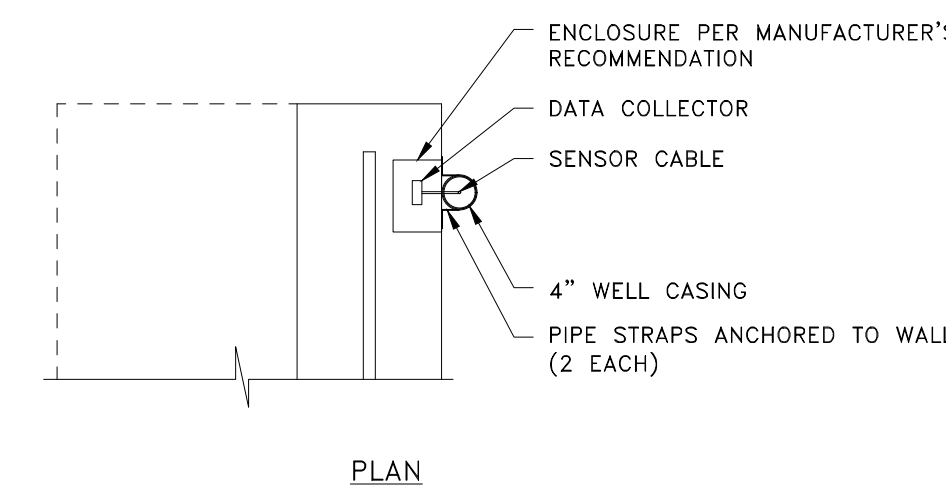

**WATER LEVEL METER NOTES:**

1. DATA LOGGER: HOBO RX3000
2. COMMUNICATION: CELLULAR WITH PREMIUM 4G DATA PLAN
3. POWER: 15 WATT SOLAR PANEL WITH BATTERY BACKUP
4. ADDED SENSORS: HOBOnet RAINFALL (INCHES) SENSOR
5. WATER LEVEL SENSOR: FRESHWATER SS LEVEL SENSOR, 30', TITANIUM/ACETAL, 2.8m CABLE, WATER LEVEL SENSOR MODULE, AND WELL CAP
6. ADDED NODULES: HOBOnet MANAGER



SCALE ADJUSTMENT GUIDE  
0" 1"  
BAR IS ONE INCH ON ORIGINAL DRAWING.

**REVISIONS:**

NO.	DATE	DESCRIPTION

PROJECT NO.: 19167.02  
DATE: NOVEMBER 2022  
SCALE: AS NOTED  
DESIGNED BY: MLP  
CHECKED BY: MED  
DRAWN BY: LMC  
APPROVED BY: ARO

MISCELLANEOUS DETAILS

SHEET NO.: